



# Spare Parts Catalog

6 S 1200 BO  
KAMAZ PUBLIC JOINT STOCK COMPANY

Material number: 1350.003.037



Pos.	Information	Amendment number
001	Use case -----	
002	Customer KAMAZ PUBLIC JOINT STOCK COMPANY	
003	City Naberezhnye Chelny	
004	DUNS 64-493-2113	
005	Vehicle / Apparatus -----	
006	Sales Name NEFAZ 5299	
007	Manufacturer KAMAZ PUBLIC JOINT STOCK COMPANY	
008	Engineering Name	
009	Product Use BUS	
010	Vehicle/Hardware Type CITY BUS	
011	SOP	
012	Engine	
013	Sales Designation	
014	Manufacturer KAMAZ PUBLIC JOINT STOCK COMPANY	
015	Eng.Displ.	
016	Cylinder	
017	Nom. power 206 kW	
018	RPM at nom. power 1900 1/min	
019	Nom. torque 1176 Nm	
020	RPM at nom. torque 1200 1/min	
021	Classification use case -----	
022	APPLICATION OF THE PRODUCT GUS	
024	APPROVAL NOTE 1 FIRST FITTING CHECK CARR.OUT	
028	DESIGNATION, CLUTCH MFZ430	
029	MANUFACTURER, CLUTCH ZF-SACHS	
032	TOTAL NUMBER OF GEARS 4	
033	NUMBER OF DRIVING GEARS 2	
034	DYNAMIC TYRE RADIUS 465 mm	
035	REAR AXLE RATIO 5.12	
036	MAXIMUM SPEED 100 km/h	



Pos.	Information	Amendment number
039	PERMISS.GROSS VEHICLE WEIGHT 16.5 t	
041	Use case -----	
042	Customer KAMAZ PUBLIC JOINT STOCK COMPANY	
043	City Naberezhnye Chelny	
044	DUNS 64-493-2113	
045	Vehicle / Apparatus -----	
046	Sales Name NEFAZ 5299	
047	Manufacturer KAMAZ PUBLIC JOINT STOCK COMPANY	
048	Engineering Name	
049	Product Use BUS	
050	Vehicle/Hardware Type CITY BUS	
051	SOP	
052	Engine	
053	Sales Designation	
054	Manufacturer Cummins Engine Co.	
055	Eng.Displ.	
056	Cylinder	
057	Nom. power 198 kW	
058	RPM at nom. power 2500 1/min	
059	Nom. torque 970 Nm	
060	RPM at nom. torque 1200 1/min	
061	Classification use case -----	
062	APPLICATION OF THE PRODUCT GUS	
064	APPROVAL NOTE 1 FIRST FITTING CHECK CARR.OUT	
068	DESIGNATION, CLUTCH MFZ430	
069	MANUFACTURER, CLUTCH ZF-SACHS	
072	TOTAL NUMBER OF GEARS 4	
073	NUMBER OF DRIVING GEARS 2	
074	DYNAMIC TYRE RADIUS 465 mm	
075	REAR AXLE RATIO 5.12	



Pos.	Information	Amendment number
076	MAXIMUM SPEED 100 km/h	
079	PERMISS.GROSS VEHICLE WEIGHT 16.5 t	
081	Product description -----	
082	INSTALLATION POS TRANSMISSION HORIZONTAL RIGHT	
083	TRANSMISSION ATTACHMENT FLANGE-MOUNTED	
084	INSTALLATION POSITION PRODUCT REAR	
085	RATIO, BOTTOM GEAR 6.75	
086	RATIO, TOP GEAR .83	
087	SET OF RATIOS SG	
088	RATIO, 1ST GEAR 6.75	
089	RATIO, 2ND GEAR 3.87	
090	RATIO, 3RD GEAR 2.36	
091	RATIO, 4TH GEAR 1.47	
092	RATIO, 5TH GEAR 1	
093	RATIO, 6TH GEAR .83	
094	RATIO, 1ST GEAR REVERSE 6.21	
095	DESIGN, SHIFT SYSTEM TURNING SHAFT	
096	POSITION, GEAR SHIFT SYSTEM VERTICAL	
097	DESIGN, SEPARATING CLUTCH FULL-SYNCHRONIZED	
098	REFERENCE LENGTH INPUT SHAFT 286 mm	
099	STANDARD TYPE INPUT SHAFT SAE	
100	NUMBER OF WEDGES INPUT SHAFT 10	
101	VERSION OF INPUT SHAFT FORM C	
102	NOMINAL DIAMETER INPUT SHAFT 1.75 in	
103	DIAMETER, RELEASE FLANGE 60 mm	
104	TYPE FIT RELEASE BEARING FLA. E8	
105	DESIGN BEARING OUTPUT STANDARD SUSPENSION	
106	OUTER DIA. OUTPUT FLANGE RA 180 mm	
107	NO.OF SCREWS OUTPUT FLANGE RA 4	
111	DIA. THREAD OUTPUT FL. SCR. RA M14	



Pos.	Information	Amendment number
113	REF. LENGTH OUTPUT FLANGE RA 88 mm	
114	THREAD PITCH OUTPUT FL SCR. RA 1.5 mm	
116	THREAD LENGTH OUTP.FL SCREW RA 50 mm	
122	DIMENSION SHIFT TURRET DIST. 184 mm	
123	MEAS. LOC. SHIFT TURRET DIST. SHIFT LEVER-LOCATION	
124	TYPE OF SHIFT CONTROL CONTROL CABLE	
133	SPRING ARRANGEMENT Q2	
134	TOOLING SET OF SPRINGS W044	
135	SPRING FORCE DETENT PLUNGER RG 240 N	
139	SELECTION PATTERN VARIANT GEAR SHIFT PATTERN 2	
140	SWITCH, REVERSE GEAR y	
141	DESIGN, RG (REV.GEAR) SWITCH OPENING SWITCH	
142	NOTE ON SWITCH, REVERSE GEAR GEAR SHIFT RAIL	
143	PROT. CAP SWITCH, REVERSE GEAR y	
144	DESIGN, CONNECTION, RG SWITCH DIN BAYONET	
146	SWITCH, NEUTRAL GEAR y	
147	DESIGN,NG(NEUTRAL GEAR)SWITCH OPENING SWITCH	
148	PROT.CAP SWITCH, NEUTRAL GEAR y	
149	DESIGN, CONNECTION, NG SWITCH DIN BAYONET	
152	REF.LENGTH,RELEASE BEAR.FLAN 170 mm	
155	DESIGN,CONN., CLUTCH HOUSING SAE 1	
156	LENGTH CLUTCH HOUSING 174 mm	
157	TYPE OF RELEASE MECHANISM PULLED	
158	VERSION OF CLUTCH CYLINDER SERVO	
159	DIAMETER, CLUTCH CYLINDER 100 mm	
160	ASSEMBLY POS. CLUTCH CYLINDER 6	
161	LENGTH TAPPET CLUTCH CYLINDER 127 mm	
162	DESIGN LUBRI.CONN. REL.BEARING WITHOUT GROOVE	
164	THREAD DIA. MTG BOLT SUSPENSION M16	
165	THREAD PITCH SUSPENSION 2 mm	



Pos.	Information	Amendment number
166	DESIGN WEAR INDICATOR CLUTCH WITH	
167	DESIGN SWITCH CLUTCH PREPARED	
173	DESIGN RELEASE BEARING WITHOUT GROOVE	
174	WRENCH SIZE, RELEASE FORK 128 mm	
176	PRESSURE ROD y	
177	RELEASE LEVER y	
190	NO PULSES PULSE SENSOR TM H70 6 IMP/U	
191	VER. PULSE SENSOR TRANSM. H70 WITH	
192	PROT. CAP PULSE SENSOR TM H70 y	
193	ASSEMBLY POS PULSE SENSOR H70 4	
194	NOTE ASS. POS PULSE SENSOR H70 INSTALLATION DRAWING	
195	VER. CONNECT. PULSE SENSOR H70 DIN BAYONET	
199	OIL CAPACITY, GEARBOX 11.5 dm <sup>3</sup>	
201	OIL GRADE PERMISSIBLE ACC. TO TE-ML02	
203	COLOR JET BLACK	
204	COLOUR CLASSIFICATION ACC. TO RAL 9005	
205	PAINTING, ZF STANDARD 915 W	
206	CODING OUTER CONSERVATION KA1	
207	SCOPE OUTER CONSERVATION T	
208	CODING INNER CONSERVATION KI2	
209	CONSERVATION SPECIFICATION ZFN 916	
210	Documents -----	
211	SCHALTGETRIEBE Drawing 1310.050.022	
212	SCHALTUNG Drawing 1311.107.016	
213	SET OF SPRINGS Drawing 1311.149.006	
214	DREHW.SCHALTUNG Drawing 1311.607.001	
215	6-SPEED GEARBOX Assembly 1350.603.004	
216	6-SPEED GEARBOX Drawing 1350.603.004	
217	KUPPLUNGSGLOCKE Drawing 6060.000.001	
218	CLUTCH HOUSING Drawing 6060.600.029	



Pos.	Information	Amendment number
219	1310.044.056 Drawing 1310.044.056	



Graphics	Pos.	Material number	Name	VKF	Amend. no.	Amend. start	Prod. no.	Material feature / tech. info.	ID
061.01.01-1	110	1310.101.047	GEARBOX HOUSING	1		00.00.0000		SG*LR*GD	3
061.01.01-1	120	1310.101.811	GEARBOX HOUSING	1		00.00.0000		LR *GD	3
061.01.01-1	122	1310.101.406	CLOSING COMPONENTS	1		00.00.0000		NA*OELANSAUG.SEK-RET*LR/LL*SOLO	6-85 3
061.02.01-1	140	1311.102.406	CONNPLATE	1		00.00.0000		L=170*D=60E8	3
061.02.01-1	150	1311.102.802	INPUT SHAFT	1		00.00.0000			3
061.02.01-1	910	1310.102.017	INPUT SHAFT	1		00.00.0000		6,75*L=286*SAE10C 1 3/4 *LAGER VERST.	3
061.03.02-1	180	1310.103.801	LAYSHAFT	1		00.00.0000			3
061.03.02-1	920	1310.103.014	LAYSHAFT	1		00.00.0000		6,75-0,83*BUS*O.N-TRIEB *SYN.D=150	3
061.04.02-1	210	1311.104.453	MAIN SHAFT	1		00.00.0000		AD=180* 4XM14X1,5X50*E/Z 6*KREUZVERZ.	3
061.04.02-1	930	1310.104.022	MAIN SHAFT	1	C0100669 6510	00.00.0000		6,75-0,83 *ZAPF.LAG.VERST*RG-LAG.INNENRG	3
061.06.02-1	230	1310.106.026	GEAR SHIFT SYSTEM	1		00.00.0000		SG*WII	3
061.06.02-1	240	1311.106.414	CONNECTING PARTS	1		00.00.0000		WII*RG-OEFF*BAJON*ADAPTER *1+2G-OHNE*3+4G-OHNE*HG-OHNE	3
061.07.01-1	282	1311.107.803	GEAR SHIFT HOUSING	1		00.00.0000		O.ABSTUETZPUNKT	3
061.07.01-1	910	1310.107.024	GEAR SHIFT HOUSING	1		00.00.0000		O.ENTLUEFTER*240N *KUGELRASTE*DW-O	3
061.07.01-1	914	1311.107.449	GEAR SHIFT SHAFT	1		00.00.0000		184,0/192,5*O.HEBEL *SCHUTZKAPPE+STOPFEN	3
061.08.02-1	926	1311.170.004	SHIFT TURRET	1		00.00.0000		184,0/192,5*GD	3
061.08.02-1	930	1311.170.005	COVER	1		00.00.0000			3
061.08.02-1	934	1311.170.801	COVER	1		00.00.0000		AUSLEGER KURZ	3
061.08.02-1	938	1311.170.022	CONNECTING PARTS	1		00.00.0000		NG-OEFF*BAJON*ADAPTER	3
061.12.03-1	922	1311.149.101	SET OF SPRINGS	1		00.00.0000		Q2*W044*184,0/279,0/373,0 *GG-RASTE SCHWACH	3
061.18.01-1	360	1311.108.013	SPEEDOMETER COVER	1		00.00.0000		E/Z 6*IMP.GEB*BAJONETT	3
061.18.01-1	370	1311.108.802	SPEEDOMETER COVER	1		00.00.0000		E-TACHO	3
061.92.59-1	480	6060.101.840	MOUNTING	1		00.00.0000		9XM18X1,5X85*1XM18X1,5X160*AL-GEHÄUSE	3
061.92.59-1	900	6060.101.572	CLUTCH HOUSING	1		00.00.0000		SAE 1*L=174,0 *M.KUPPL.VERST-6	3
061.92.59-1	920	6060.101.838	MOUNTING	1		00.00.0000		LAGERBOCK	3

VKF Incidence factor

ID Identification (output code)





Graphics	Pos.	Material number	Name	VKF	Amend. no.	Amend. start	Prod. no.	Material feature / tech. info.	ID
061.93.30-1	910	6060.168.001	CLUTCH RELEASE DEVICE	1		00.00.0000		GABEL SW128	3

**VKF** Incidence factor

**ID** Identification (output code)

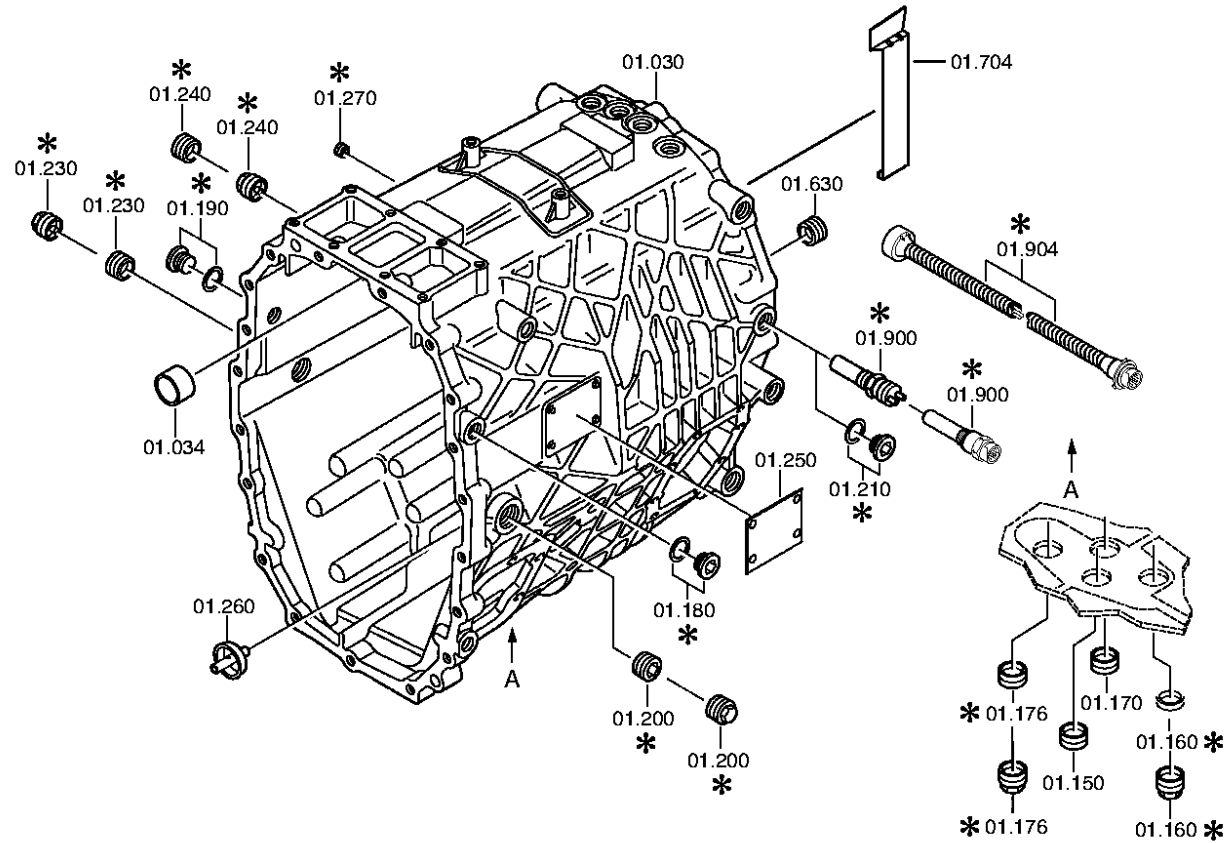

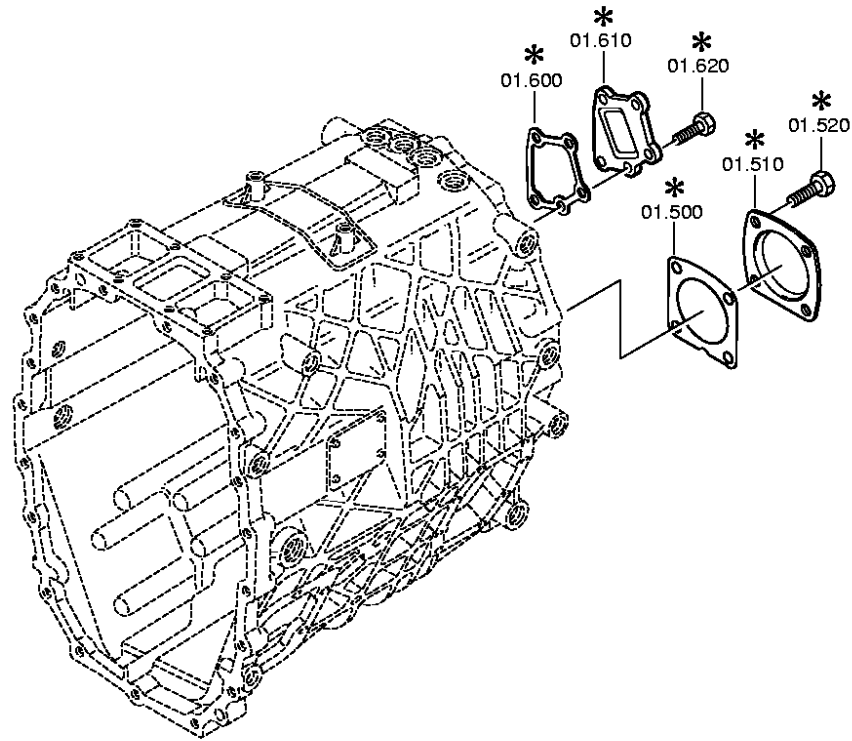



Bildtafel:  
 Figure: 061.01.80  
 Figure:  
 Figura:

je nach Stücklistenausführung  
 depending on spec. number  
 \* suivant la nomenclature  
 secondo la distinta base

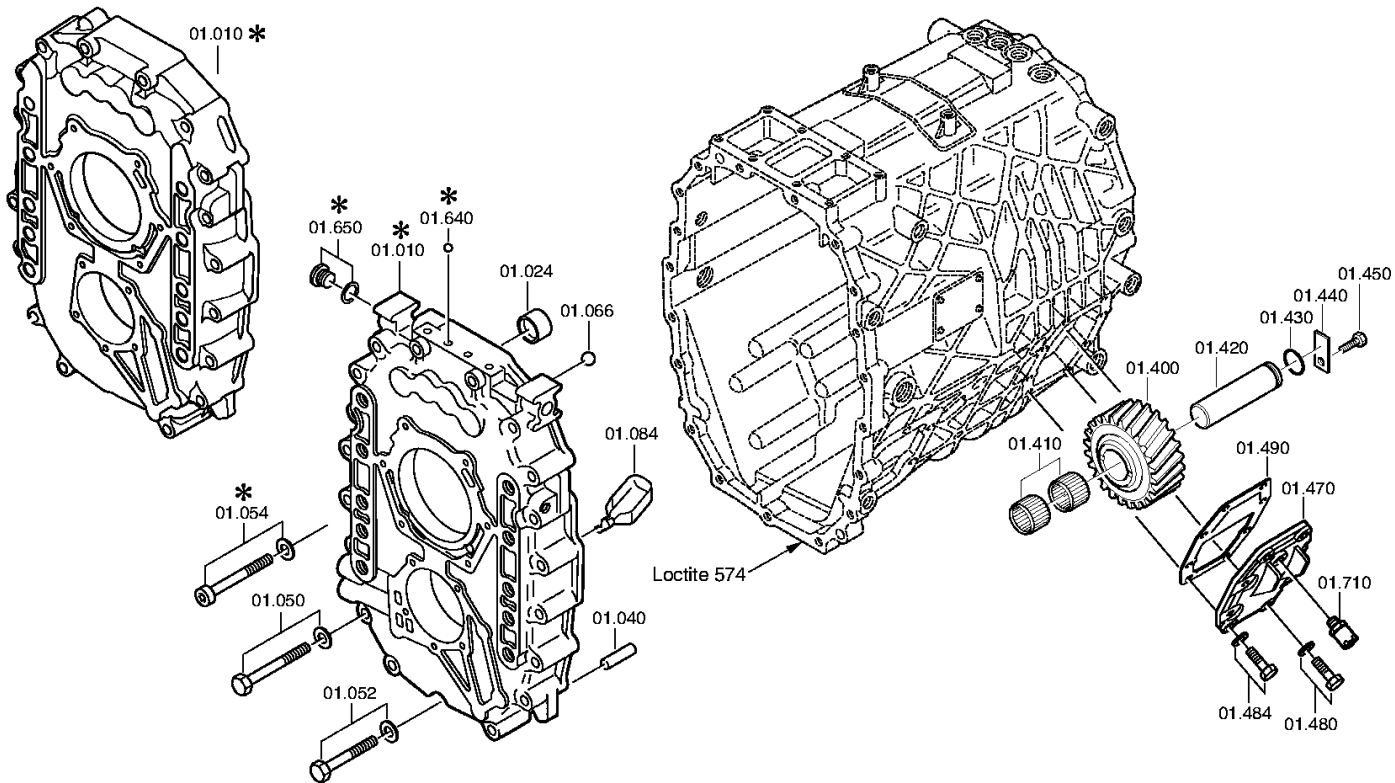



Pos.	Material number	Name	VKF	Amend. no.	Amend. start	Prod. no.	Material feature / tech. info.	OTK	External material no.	ID	Weight	SP
10	1310.301.106	HOUSING	1	C0100398 6F10	00.00.0000	00.00.0000				5	0,000	
24	0501.311.613	JOINT BEARING	2		00.00.0000		22,0X28,0X16,0*INA			5	0,000	
30	1310.301.023	HOUSING	1		00.00.0000		II			5	0,000	
34	0501.311.613	JOINT BEARING	2		00.00.0000		22,0X28,0X16,0*INA			5	0,000	
40	0631.306.231	CYLINDRICAL PIN	2	C0100679 1510	00.00.0000	00.00.0000	12X28			5	0,000	
50	---	HEXAGON BOLT	17	C0100590 1910	00.00.0000	00.00.0000	M10X80 DIN931ALT/10.9 A3C			3	0,000	
---	0636.010.668	HEXAGON BOLT	17		00.00.0000		M10X80			5	0,000	
---	0630.001.048	WASHER	17		00.00.0000					5	3,400	
52	---	HEXAGON BOLT	2	C0100590 2010	00.00.0000	00.00.0000	M10X55 DIN931ALT/10.9 A3C			3	0,000	
---	0636.010.669	HEXAGON BOLT	2		00.00.0000		M10X55			5	0,000	
---	0630.001.048	WASHER	2		00.00.0000					5	3,400	
66	0635.460.057	BALL	1	C0100543 1610	00.00.0000	00.00.0000	10,319			5	0,000	
84	1310.301.021	OIL TUBE	1		00.00.0000					5	0,000	
150	---	SCREW PLUG	1	C0100729 6510	00.00.0000	00.00.0000	M24X1,5 * 50N.M*O. DICHTRG.			3	0,000	
---	0736.301.022	SCREW PLUG	1		00.00.0000		M24X1,5 IN 0736 301 020(2)			5	0,000	
160	---	SCREW PLUG	1	C0100729 6510	00.00.0000	00.00.0000	M24X1,5 * 50N.M*O. DICHTRG.			3	0,000	
---	0736.301.022	SCREW PLUG	1		00.00.0000		M24X1,5 IN 0736 301 020(2)			5	0,000	
170	---	SCREW PLUG	1	C0100729 6510	00.00.0000	00.00.0000	M24X1,5 * 50N.M*O. DICHTRG.			3	0,000	
---	0736.301.022	SCREW PLUG	1		00.00.0000		M24X1,5 IN 0736 301 020(2)			5	0,000	
176	---	SCREW PLUG	1		00.00.0000		M24X1,5 * 50N.M*O. DICHTRG.			3	0,000	
---	0736.303.005	SCREW PLUG	1	C0100697 5410	00.00.0000	00.00.0000				5	0,000	
200	---	SCREW PLUG	1		00.00.0000		M24X1,5 * 50N.M*O. DICHTRG.			3	0,000	
---	0736.301.022	SCREW PLUG	1	C0100559 3A10	00.00.0000	00.00.0000	M24X1,5 IN 0736 301 020(2)			5	0,000	

VKF Incidence factor

OTK Optional technical kit

ID Identification (output code)

SP Supplier plant



Pos.	Material number	Name	VKF	Amend. no.	Amend. start	Prod. no.	Material feature / tech. info.	OTK	External material no.	ID	Weight	SP
210	---	SCREW PLUG	1		00.00.0000		M18X1,5 * 35N.M* DICHRING			3	0,000	
---	0636.302.021	SCREW PLUG	1		00.00.0000		M18X1,5			5	0,090	
---	0634.801.062	SEALING RING	1	C0100577 3010	00.00.0000	00.00.0000	18X24			5	0,001	
230	---	SCREW PLUG	1		00.00.0000		M24X1,5 * 50N.M*O. DICHRG.			3	0,000	
---	0736.305.016	SCREW PLUG	1	C0100559 3A10	00.00.0000	00.00.0000	M24X1,5 MAGNET			5	0,000	
240	---	SCREW PLUG	1		00.00.0000		M24X1,5 * 50N.M*O. DICHRG.			3	0,000	
---	0736.301.022	SCREW PLUG	1	C0100559 3A10	00.00.0000	00.00.0000	M24X1,5 IN 0736 301 020(2)			5	0,000	
250	---	TYPE PLATE	1	C0100105 6E10	00.00.0000	00.00.0000	WTB			3	0,000	
---	0730.365.241	TYPE PLATE	1		00.00.0000		EINHEITSSCH. VERDREHSICHER			5	0,000	
---	0730.365.171	TYPE PLATE	1		00.00.0000		ZF HUNGARIA			5	0,000	
260	1310.201.003	OIL TUBE	1	C0100669 6510	00.00.0000	00.00.0000	KPL. IN 1310 212 004(3)			3	0,000	
270	---	SCREW PLUG	1	C0100705 9810	00.00.0000	00.00.0000	M10X1 * 10N.M*O. DICHRG.			3	0,000	
---	0636.301.039	SCREW PLUG	1		00.00.0000		M10X1			5	5	
400	1310.305.013	IDLER GEAR	1		00.00.0000					5	0,000	
410	0750.115.233	NEEDLE CAGE	2	C0100507 0510	00.00.0000	00.00.0000	WTB 30,0X38,0X30,0			3	0,000	
420	1310.305.001	PIN	1		00.00.0000					5	0,000	
430	0634.316.221	O-RING	1	C0100158 7A10	00.00.0000	00.00.0000	26X2			5	0,000	
440	1310.305.004	TAB WASHER	1	C0100512 8410	00.00.0000	00.00.0000	ENTHALT.IN 1311 305 008(2)			5	0,000	
450	0636.015.225	HEXAGON BOLT	1		00.00.0000		M8X18			5	10	
470	1310.301.024	COVER	1	C0100514 7410	00.00.0000	00.00.0000	ENTHALT.IN 1310 301 038(1)			5	0,000	

VKF Incidence factor

OTK Optional technical kit

ID Identification (output code)

SP Supplier plant



Pos.	Material number	Name	VKF	Amend. no.	Amend. start	Prod. no.	Material feature / tech. info.	OTK	External material no.	ID	Weight	SP
480	---	HEXAGON BOLT	7	C0100619 9710	00.00.0000	00.00.0000	M8X35 ISO4017/8.8 A3C			3	0,000	
---	0636.015.277	HEXAGON BOLT	7		00.00.0000		M8X35			5	15	
---	0630.001.075	WASHER	7		00.00.0000					5	0,002	
484	---	HEXAGON BOLT	1	C0100619 9710	00.00.0000	00.00.0000	M8X35 ISO4017/8.8 A3C			3	0,000	
---	0636.015.277	HEXAGON BOLT	1		00.00.0000		M8X35			5	15	
---	0630.001.075	WASHER	1		00.00.0000					5	0,002	
490	0501.313.195	SCREEN SHEET	1	C0100527 6510	00.00.0000	00.00.0000				5	0,000	
500	1238.308.201	GASKET	1		00.00.0000		ENTHALT.IN 1238 308 202(2)			5	0,000	
510	1304.301.034	COVER	1		00.00.0000					5	0,000	
520	---	HEXAGON BOLT	4		00.00.0000		M12X25 DIN933ALT/8.8 A3C			3	0,000	
---	0636.016.178	HEXAGON BOLT	4		00.00.0000		M12X25			5	0,035	
600	0501.313.640	GASKET	1		00.00.0000					5	0,000	
610	1310.301.064	COVER	1		00.00.0000					5	0,000	
620	0636.015.405	HEXAGON BOLT	5		00.00.0000		M10X28			5	0,000	
630	---	SCREW PLUG	1		00.00.0000		M24X1,5 * 50N.M*O. DICHTRG.			3	0,000	
---	0736.301.022	SCREW PLUG	1	C0100559 3A10	00.00.0000	00.00.0000	M24X1,5 IN 0736 301 020(2)			5	0,000	
710	---	BREATHER	1		00.00.0000		M10X1KEG			3	0,000	
---	0501.202.797	BREATHER	1		00.00.0000		KPL.			3	30	

VKF Incidence factor

OTK Optional technical kit

ID Identification (output code)

SP Supplier plant

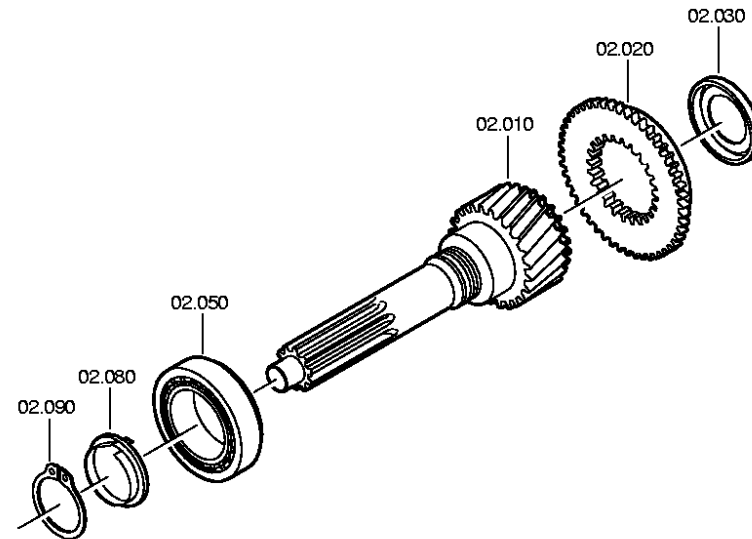



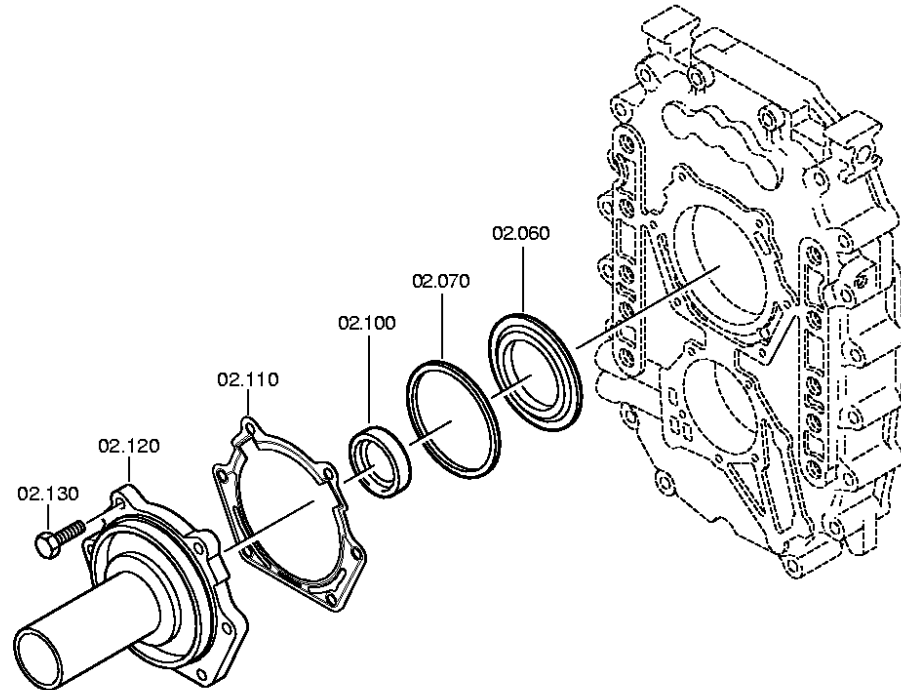



Pos.	Material number	Name	VKF	Amend. no.	Amend. start	Prod. no.	Material feature / tech. info.	OTK	External material no.	ID	Weight	SP
10	1310.302.001	INPUT SHAFT	1		00.00.0000		ENTHALT.IN 1310 302 009(0)			5	0,000	
20	1310.302.023	CLUTCH BODY	1		00.00.0000		ENTHALT.IN 1311 302 049(1)			5	0,000	
30	0501.313.171	OIL DAM	1		00.00.0000					5	0,000	
50	0750.117.347	TAROLLBEARING	1	C0100763 3610	00.00.0000	00.00.0000	WTB 70,0X115,0X29,0			3	1,200	
60	1311.302.012	OIL DAM	1		00.00.0000					5	0,000	
70	---	WASHER	1	C0100511 5310	00.00.0000	00.00.0000	WTB 0730 006 730(2)-A= 1,00-1,90( ABSTUFUNG:0,05MM)			3	0,000	
---	0730.006.750	WASHER	1		00.00.0000		A=1,90 IN 0730 006 730(2)			5	0,000	
---	0730.006.729	WASHER	1		00.00.0000		A=1,85 IN 0730 006 730(2)			5	0,000	
---	0730.006.749	WASHER	1		00.00.0000		A=1,80 IN 0730 006 730(2)			5	0,000	
---	0730.006.728	WASHER	1		00.00.0000		A=1,75 IN 0730 006 730(2)			5	0,000	
---	0730.006.748	WASHER	1		00.00.0000		A=1,70 IN 0730 006 730(2)			5	0,000	
---	0730.006.727	WASHER	1		00.00.0000		A=1,65 IN 0730 006 730(2)			5	0,000	
---	0730.006.747	WASHER	1		00.00.0000		A=1,60 IN 0730 006 730(2)			5	0,000	
---	0730.006.726	WASHER	1		00.00.0000		A=1,55 IN 0730 006 730(2)			5	0,000	
---	0730.006.746	WASHER	1		00.00.0000		A=1,50 IN 0730 006 730(2)			5	0,000	
---	0730.006.725	WASHER	1		00.00.0000		A=1,45 IN 0730 006 730(2)			5	0,000	
---	0730.006.745	WASHER	1		00.00.0000		A=1,40 IN 0730 006 730(2)			5	0,000	
---	0730.006.724	WASHER	1		00.00.0000		A=1,35 IN 0730 006 730(2)			5	0,000	
---	0730.006.744	WASHER	1		00.00.0000		A=1,30 IN 0730 006 730(2)			5	0,000	
---	0730.006.723	WASHER	1		00.00.0000		A=1,25 IN 0730 006 730(2)			5	0,000	
---	0730.006.743	WASHER	1		00.00.0000		A=1,20 IN 0730 006 730(2)			5	0,000	
---	0730.006.722	WASHER	1		00.00.0000		A=1,15 IN 0730 006 730(2)			5	0,000	
---	0730.006.742	WASHER	1		00.00.0000		A=1,10 IN 0730 006 730(2)			5	0,000	
---	0730.006.721	WASHER	1		00.00.0000		A=1,05 IN 0730 006 730(2)			5	0,000	
---	0730.006.741	WASHER	1		00.00.0000		A=1,00 IN 0730 006 730(2)			5	0,000	
80	1311.202.002	SHEET	1		00.00.0000		KPL.			3	0,000	
90	0630.501.034	RETAINING RING	1		00.00.0000		48X1,75			5	7	
100	0750.111.149	SHAFT SEAL	1	C0100550 9710	00.00.0000	00.00.0000	WTB 48X65X10			3	0,000	
110	0501.317.402	GASKET	1	C0100999 0D10	00.00.0000	00.00.0000				5	0,000	
120	1310.302.016	CONNPLATE	1		00.00.0000		ENTHALT.IN 1311 302 031(0)			5	0,000	

VKF Incidence factor

OTK Optional technical kit

ID Identification (output code)

SP Supplier plant



Pos.	Material number	Name	VKF	Amend. no.	Amend. start	Prod. no.	Material feature / tech. info.	OTK	External material no.	ID	Weight	SP
130	0636.015.411	HEXAGON BOLT	6		00.00.0000		M8X28			5	0,000	

**VKF** Incidence factor

**OTK** Optional technical kit

**ID** Identification (output code)

**SP** Supplier plant

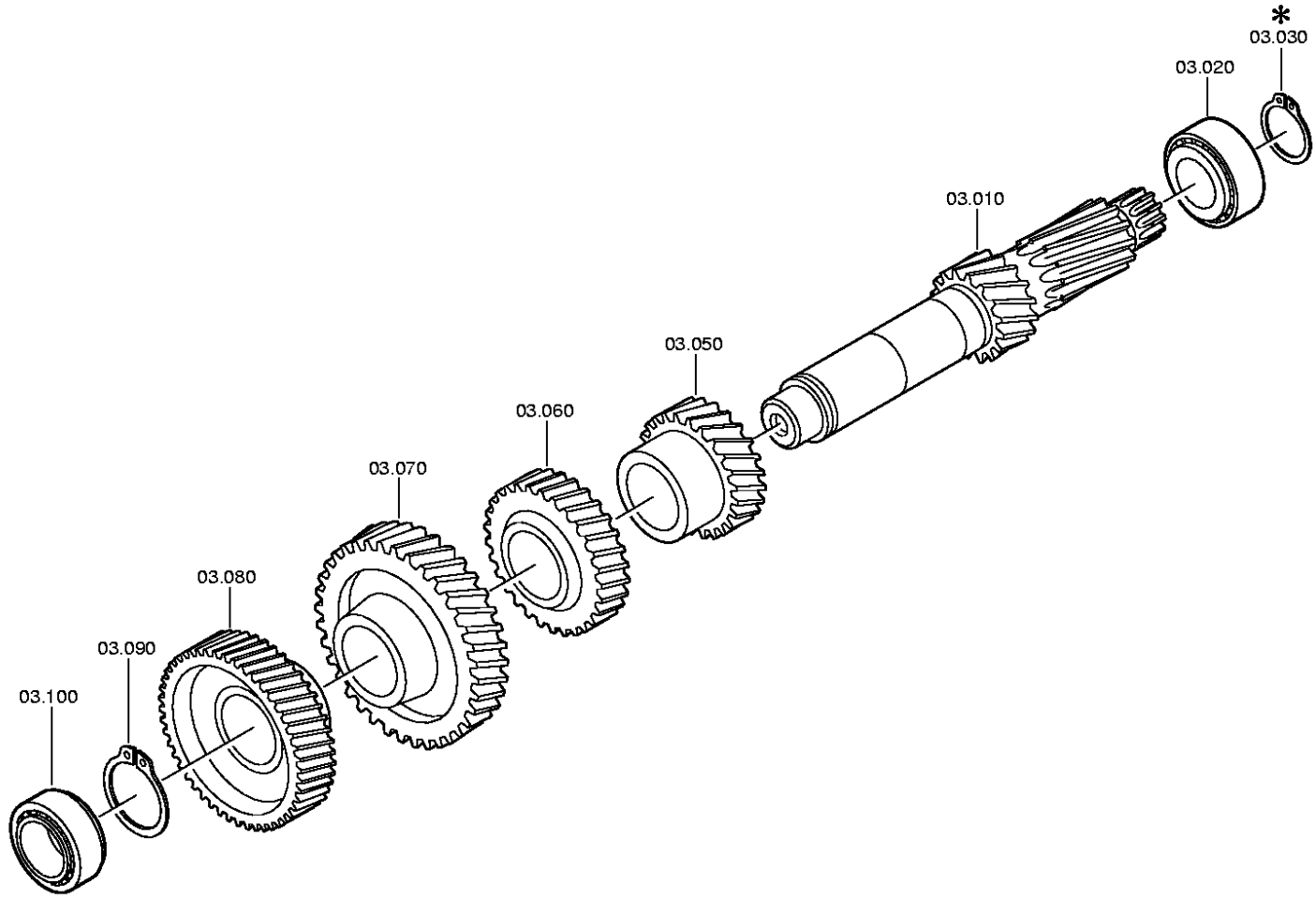

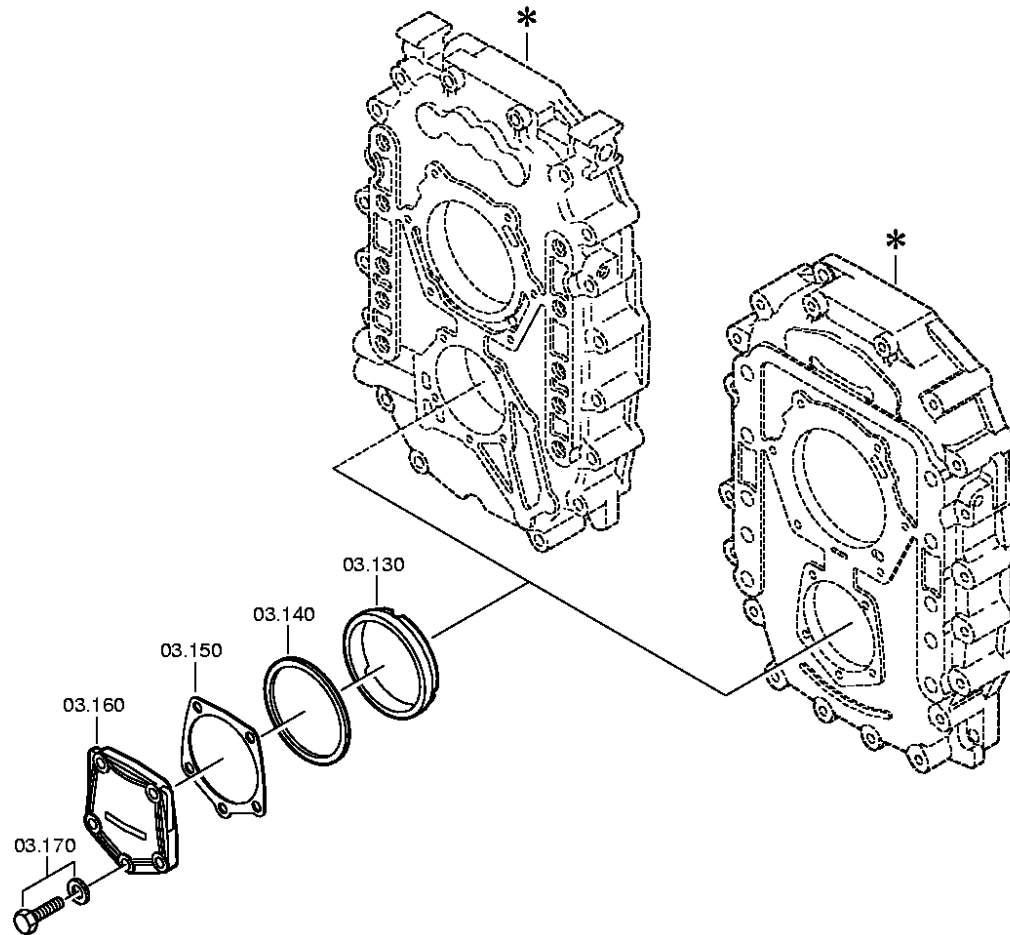



Pos.	Material number	Name	VKF	Amend. no.	Amend. start	Prod. no.	Material feature / tech. info.	OTK	External material no.	ID	Weight	SP
10	1310.303.076	LAYSHAFT	1	C0100410 9A10	00.00.0000	00.00.0000	ENTHALT.IN 1310 303 034(1)			5	0,000	
20	1246.203.008	TAROLLBEARING	1		00.00.0000		KPL.ABTR*S6-66/85=ANTR			3	0,000	
50	1310.303.031	HELICAL GEAR	1		00.00.0000		3G/Z24 IN 1311 303 009(1)			5	0,000	
60	1310.303.051	HELICAL GEAR	1		00.00.0000		4G/Z32 IN 1311 303 036(1)			5	0,000	
70	1310.303.033	HELICAL GEAR	1		00.00.0000		6G/Z45 IN 1311 303 005(1)			5	0,000	
80	1310.303.032	HELICAL GEAR	1		00.00.0000		KON/Z47 IN 1311 303 003(1)			5	0,000	
90	---	RETAINING RING	1	C0100547 3310	00.00.0000	00.00.0000	WTB -A= 1,80- 2,50( ABSTUFUNG:0,10MM)			3	0,000	
---	0630.501.047	RETAINING RING	1		00.00.0000		72X2,5			5	0,020	
---	0630.501.190	RETAINING RING	1		00.00.0000		72X2,4			5	0,000	
---	0630.501.189	RETAINING RING	1		00.00.0000		72X2,3			5	0,000	
---	0630.501.365	RETAINING RING	1		00.00.0000		72X2,2			5	0,000	
---	0630.501.364	RETAINING RING	1		00.00.0000		72X2,1			5	0,000	
---	0630.501.363	RETAINING RING	1		00.00.0000		72X2			5	0,000	
---	0630.501.366	RETAINING RING	1	C0100554 2510	00.00.0000	00.00.0000	72X1,9			5	0,000	
---	0630.501.373	RETAINING RING	1	C0100622 9710	00.00.0000	00.00.0000	72X1,8			5	0,000	
100	0750.117.083	TAROLLBEARING	1	C0100653 4310	00.00.0000	00.00.0000	WTB 50,8X95,2X27,7			3	0,000	
130	0730.162.555	RING	1	C0100516 3310	00.00.0000	00.00.0000	A=16,00			5	0,000	
140	---	SHIM	1	C0100602 6010	00.00.0000	00.00.0000	WTB 0730 104 697(2)-A= 1,60- 2,80( ABSTUFUNG:0,05MM)			3	0,000	
---	0730.110.636	SHIM	1	C0100799 3910	00.00.0000	00.00.0000	A=2,80 IN 0730 104 697(2)			5	0,000	
---	0730.110.635	SHIM	1	C0100799 3910	00.00.0000	00.00.0000	A=2,75 IN 0730 104 697(2)			5	0,000	
---	0730.103.271	SHIM	1	C0100799 3910	00.00.0000	00.00.0000	A=2,70 IN 0730 104 697(2)			5	0,000	
---	0730.103.270	SHIM	1	C0100799 3910	00.00.0000	00.00.0000	A=2,65 IN 0730 104 697(2)			5	0,000	
---	0730.103.269	SHIM	1	C0100799 3910	00.00.0000	00.00.0000	A=2,60 IN 0730 104 697(2)			5	0,000	

VKF Incidence factor

OTK Optional technical kit

ID Identification (output code)

SP Supplier plant



Pos.	Material number	Name	VKF	Amend. no.	Amend. start	Prod. no.	Material feature / tech. info.	OTK	External material no.	ID	Weight	SP
---	0730.103.268	SHIM	1	C0100799 3910	00.00.0000	00.00.0000	A=2,55 IN 0730 104 697(2)			5	0,000	
---	0730.103.267	SHIM	1	C0100799 3910	00.00.0000	00.00.0000	A=2,50 IN 0730 104 697(2)			5	0,000	
---	0730.103.266	SHIM	1	C0100799 3910	00.00.0000	00.00.0000	A=2,45 IN 0730 104 697(2)			5	0,000	
---	0730.103.265	SHIM	1		00.00.0000		A=2,40 IN 0730 104 697(2)			5	0,000	
---	0730.103.264	SHIM	1		00.00.0000		A=2,35 IN 0730 104 697(2)			5	0,000	
---	0730.103.263	SHIM	1		00.00.0000		A=2,30 IN 0730 104 697(2)			5	0,000	
---	0730.104.619	SHIM	1		00.00.0000		A=2,25 IN 0730 104 697(2)			5	0,000	
---	0730.100.972	SHIM	1		00.00.0000		A=2,20 IN 0730 104 697(2)			5	0,000	
---	0730.101.551	SHIM	1		00.00.0000		A=2,15 IN 0730 104 697(2)			5	0,000	
---	0730.100.973	SHIM	1		00.00.0000		A=2,10 IN 0730 104 697(2)			5	0,000	
---	0730.101.552	SHIM	1		00.00.0000		A=2,05 IN 0730 104 697(2)			5	0,000	
---	0730.100.974	SHIM	1		00.00.0000		A=2,00 IN 0730 104 697(2)			5	0,000	
---	0730.101.553	SHIM	1		00.00.0000		A=1,95 IN 0730 104 697(2)			5	0,000	
---	0730.100.975	SHIM	1		00.00.0000		A=1,90 IN 0730 104 697(2)			5	0,000	
---	0730.101.554	SHIM	1		00.00.0000		A=1,85 IN 0730 104 697(2)			5	0,000	
---	0730.100.976	SHIM	1		00.00.0000		A=1,80 IN 0730 104 697(2)			5	0,000	
---	0730.101.555	SHIM	1		00.00.0000		A=1,75 IN 0730 104 697(2)			5	0,000	
---	0730.101.309	SHIM	1		00.00.0000		A=1,70 IN 0730 104 697(2)			5	0,000	
---	0730.101.556	SHIM	1		00.00.0000		A=1,65 IN 0730 104 697(2)			5	0,000	
---	0730.101.310	SHIM	1		00.00.0000		A=1,60 IN 0730 104 697(2)			5	0,000	
150	0501.313.044	GASKET	1	C0100694 8010	00.00.0000	00.00.0000				5	0,000	
160	1310.301.035	COVER	1	C0100568 0610	00.00.0000	00.00.0000				5	0,000	
170	---	HEXAGON BOLT	5	C0100568 0610	00.00.0000	00.00.0000	M8X35 ISO4017/8.8 A3C			3	0,000	
---	0636.015.277	HEXAGON BOLT	5		00.00.0000		M8X35			5	15	
---	0630.001.075	WASHER	5		00.00.0000					5	0,002	

VKF Incidence factor

OTK Optional technical kit

ID Identification (output code)

SP Supplier plant

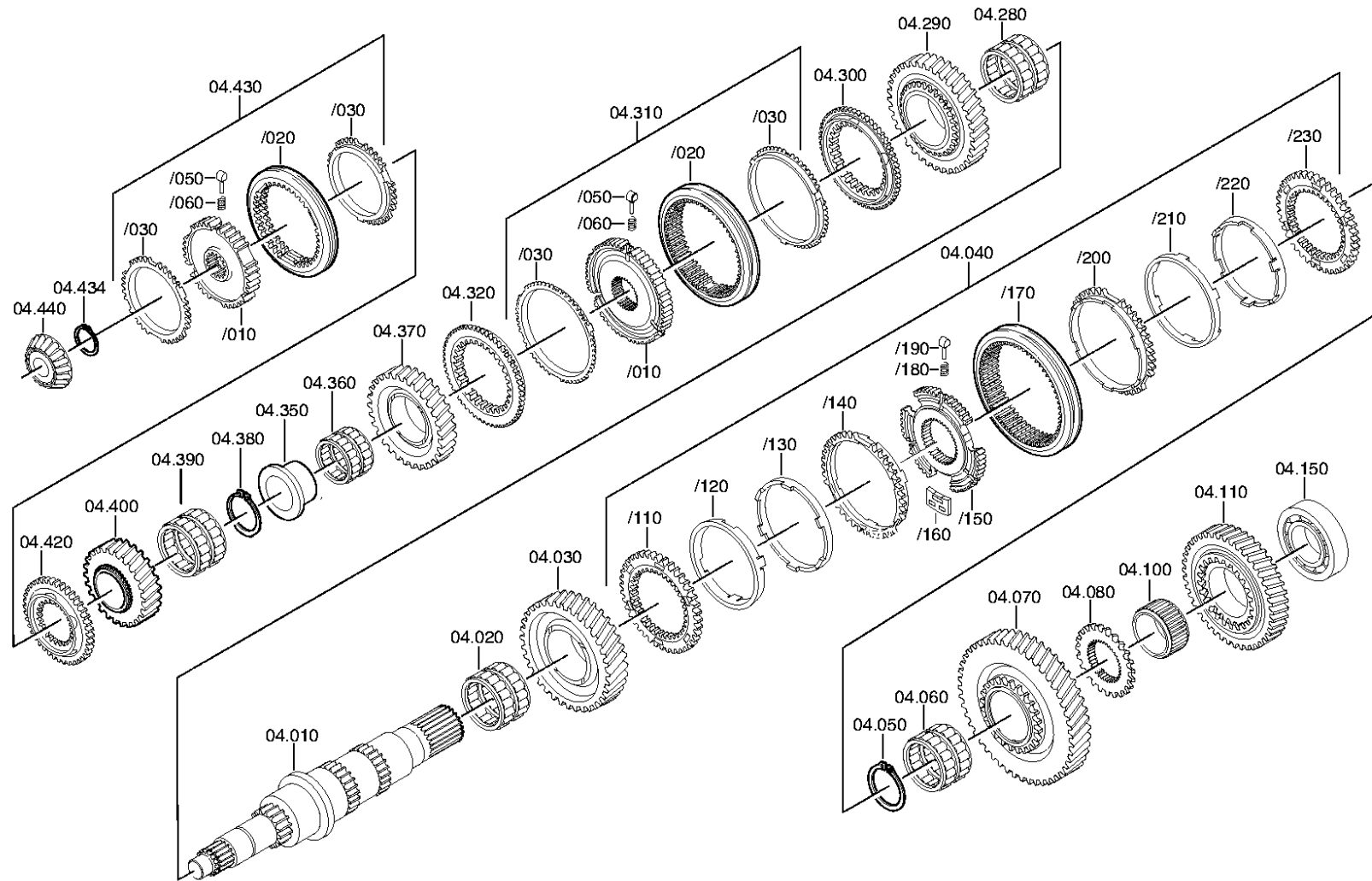



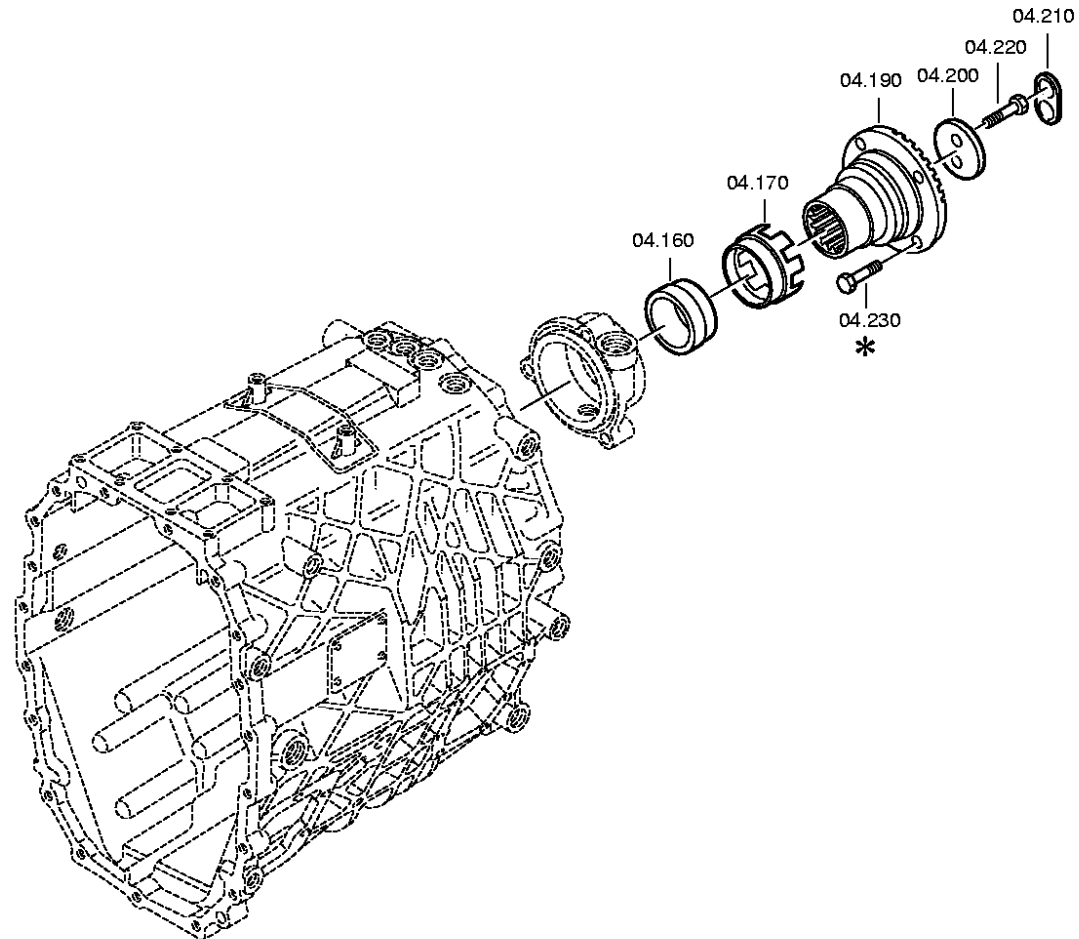



Pos.	Material number	Name	VKF	Amend. no.	Amend. start	Prod. no.	Material feature / tech. info.	OTK	External material no.	ID	Weight	SP
10	1311.304.248	MAIN SHAFT	1	C0100669 6210	00.00.0000	00.00.0000				5	0,000	
20	0735.321.106	NEEDLE CAGE	1		00.00.0000		80,0X88,0X48,0 FA.INA			5	0,000	
30	1310.304.012	HELICAL GEAR	1		00.00.0000		2G/Z43 IN 1310 304 116(1)			5	0,000	
40	1310.204.026	SYNCHRONIZER	1	C0100546 5A10	00.00.0000	00.00.0000	KPL.1+2G*DK			3	0,000	
/110	1312.304.106	CLUTCH DISC	1		00.00.0000					5	0,000	
/120	1268.304.424	INTERNAL RING	1		00.00.0000					5	0,000	
/130	1268.304.494	INTERMRING	1		00.00.0000		ENTHALT.IN 6002 306 153(0)			5	0,000	
/140	1268.304.525	OUTER RING	1		00.00.0000		ENTHALT.IN 1310 304 095(1)			5	0,000	
/150	1310.304.157	SYNCHROBODY	1		00.00.0000		1+2G			5	0,000	
/160	1312.304.159	COUPLING ELEMENT	3	C0100689 2A10	00.00.0000	00.00.0000				5	0,030	
/170	1310.304.175	SLIDING SLEEVE	1	C0100731 7F10	00.00.0000	00.00.0000				5	0,000	
/180	0732.040.409	COMPRSPRING	3		00.00.0000					5	0,002	
/190	1297.304.436	PRESSURE PIECE	3		00.00.0000					5	0,004	
/200	1268.304.525	OUTER RING	1		00.00.0000		ENTHALT.IN 1310 304 095(1)			5	0,000	
/210	1268.304.494	INTERMRING	1		00.00.0000		ENTHALT.IN 6002 306 153(0)			5	0,000	
/220	1268.304.424	INTERNAL RING	1		00.00.0000					5	0,000	
/230	1312.304.106	CLUTCH DISC	1		00.00.0000					5	0,000	
50	---	RETAINING RING	1		00.00.0000		WTB -A= 3,80- 4,00( ABSTUFUNG:0,10MM)			3	0,000	
---	0630.531.087	RETAINING RING	1		00.00.0000		75X4			5	0,000	
---	0630.531.102	RETAINING RING	1		00.00.0000		75X3,9			5	0,000	
---	0630.531.103	RETAINING RING	1		00.00.0000		75X3,8			5	0,000	
60	0735.321.108	NEEDLE CAGE	1		00.00.0000		75,0X83,0X50,0 FA.INA			5	0,000	
70	1310.304.011	HELICAL GEAR	1		00.00.0000		1G/Z50 IN 1310 304 114(1)			5	0,000	
80	1311.304.250	CLUTCH BODY	1		00.00.0000		ENTHALT.IN 1311 304 070(2)			5	0,000	
100	0735.298.255	NEEDLE BEARING	1	C0100422 7A10	00.00.0000	00.00.0000	70,0X86,0X42,5 FA.INA KPL			5	0,000	
110	1310.304.200	HELICAL GEAR	1	C0100065 6A10	00.00.0000	00.00.0000	RG			5	0,000	
150	0735.370.730	TAROLLBEARING	1		00.00.0000		60,0X120,0X29,7 FA. TIMKEN			5	0,000	

VKF Incidence factor

OTK Optional technical kit

ID Identification (output code)

SP Supplier plant



Pos.	Material number	Name	VKF	Amend. no.	Amend. start	Prod. no.	Material feature / tech. info.	OTK	External material no.	ID	Weight	SP
160	1311.304.055	BUSH	1		00.00.0000		ENTHALT.IN 1311 304 165(2)			5	0,000	
170	1311.304.056	COUNTING DISC	1		00.00.0000					5	0,000	
190	1310.304.134	OUTPUT FLANGE	1		00.00.0000		ENTHALT.IN 1310 304 009(1)			5	0,000	
200	1250.304.218	WASHER	1		00.00.0000		ENTHALT.IN 1240 304 427(2)			5	0,000	
210	---	TAB WASHER	1		00.00.0000					3	0,000	
---	1250.304.353	TAB WASHER	1		00.00.0000		ENTHALT.IN 1313 304 043(2)			5	14	
220	---	HEXAGON BOLT	2		00.00.0000		M12X50 DIN933ALT/8.8 A3C			3	0,000	
---	0636.016.180	HEXAGON BOLT	2	C0100713 3210	00.00.0000	00.00.0000	M12X50			5	55	
230	---	HEXAGON BOLT	4		00.00.0000		M14X1,5X50 * SCHUTZHUELSE			3	0,000	
---	0636.021.059	HEXAGON BOLT	4		00.00.0000		M14X1,5X50			5	0,070	
280	0735.321.106	NEEDLE CAGE	1		00.00.0000		80,0X88,0X48,0 FA.INA			5	0,000	
290	1310.304.085	HELICAL GEAR	1		00.00.0000		3G/Z35 IN 1310 304 084(1)			5	0,000	
300	1312.304.027	CLUTCH BODY	1		00.00.0000		ENTHALT.IN 1310 304 107(1)			5	0,000	
310	1310.204.011	SYNCHRONIZER	1		00.00.0000		KPL.3+4G*KW*D=150			3	0,000	
/10	1310.304.080	SYNCHROBODY	1		00.00.0000		ENTHALT.IN 1310 304 102(1)			5	0,000	
/20	1310.304.202	SLIDING SLEEVE	1	C0100537 7A10	00.00.0000	00.00.0000				5	0,000	
/30	1297.304.484	SYNCHRO RING	2	C0100396 9B10	00.00.0000	00.00.0000				5	0,000	
/50	1297.304.436	PRESSURE PIECE	3		00.00.0000					5	0,004	
/60	0732.040.409	COMPRSPRING	3	C0100731 7F10	00.00.0000	00.00.0000				5	0,002	
320	1312.304.027	CLUTCH BODY	1		00.00.0000		ENTHALT.IN 1310 304 107(1)			5	0,000	
350	1311.304.124	FLANGE BUSH	1		00.00.0000					5	0,000	
360	0735.320.493	NEEDLE CAGE	1		00.00.0000		70,0X78,0X37,0 FA.INA			5	0,000	
370	1310.304.088	HELICAL GEAR	1		00.00.0000		4G/Z29 IN 1310 304 087(1)			5	0,000	
380	---	RETAINING RING	1	C0100561 5C10	00.00.0000	00.00.0000	WTB -A= 2,00- 2,30( ABSTUFUNG:0,10MM)			3	0,000	
---	0730.501.727	RETAINING RING	1		00.00.0000		A=2,30			5	0,000	
---	0730.501.726	RETAINING RING	1		00.00.0000		A=2,20			5	0,000	
---	0730.501.725	RETAINING RING	1		00.00.0000		A=2,10			5	0,000	
---	0730.501.724	RETAINING RING	1		00.00.0000		A=2,00			5	0,000	

VKF Incidence factor

OTK Optional technical kit

ID Identification (output code)

SP Supplier plant



Pos.	Material number	Name	VKF	Amend. no.	Amend. start	Prod. no.	Material feature / tech. info.	OTK	External material no.	ID	Weight	SP
390	0735.321.678	NEEDLE CAGE	1	C0100442 0F10	00.00.0000	00.00.0000	52,0X60,0X23,0 FA.INA			5	0,000	
400	1310.304.091	HELICAL GEAR	1		00.00.0000		6G/Z23 IN 1310 304 090(1)			5	0,000	
420	1311.304.009	CLUTCH BODY	1		00.00.0000					5	0,000	
430	1311.204.022	SYNCHRONIZER	1		00.00.0000		KPL.5+6G			3	0,000	
/10	1311.304.226	SYNCHROBODY	1		00.00.0000					5	0,000	
/20	1304.304.664	SLIDING SLEEVE	1	C0100128 0A10	00.00.0000	00.00.0000	ZF-BK119			5	0,000	
/30	1311.304.255	SYNCHRORING	2	C0100396 9B10	00.00.0000	00.00.0000	ZF BK119			5	0,000	
/50	1297.304.436	PRESSURE PIECE	3	C0100575 4510	00.00.0000	00.00.0000				5	0,004	
/60	0732.040.409	COMPRSPRING	3	C0100731 7F10	00.00.0000	00.00.0000				5	0,002	
434	---	RETAINING RING	1		00.00.0000		WTB -A= 2,30- 2,50( ABSTUFUNG:0,10MM)			3	0,000	
---	0630.531.061	RETAINING RING	1		00.00.0000		48X2,5			5	12	
---	0630.501.126	RETAINING RING	1		00.00.0000		48X2,4			5	0,000	
---	0630.501.127	RETAINING RING	1		00.00.0000		48X2,3			5	0,000	
440	0750.117.562	TAROLLBEARING	1		00.00.0000		WTB 28,0X32,0			3	0,000	

VKF Incidence factor

OTK Optional technical kit

ID Identification (output code)

SP Supplier plant

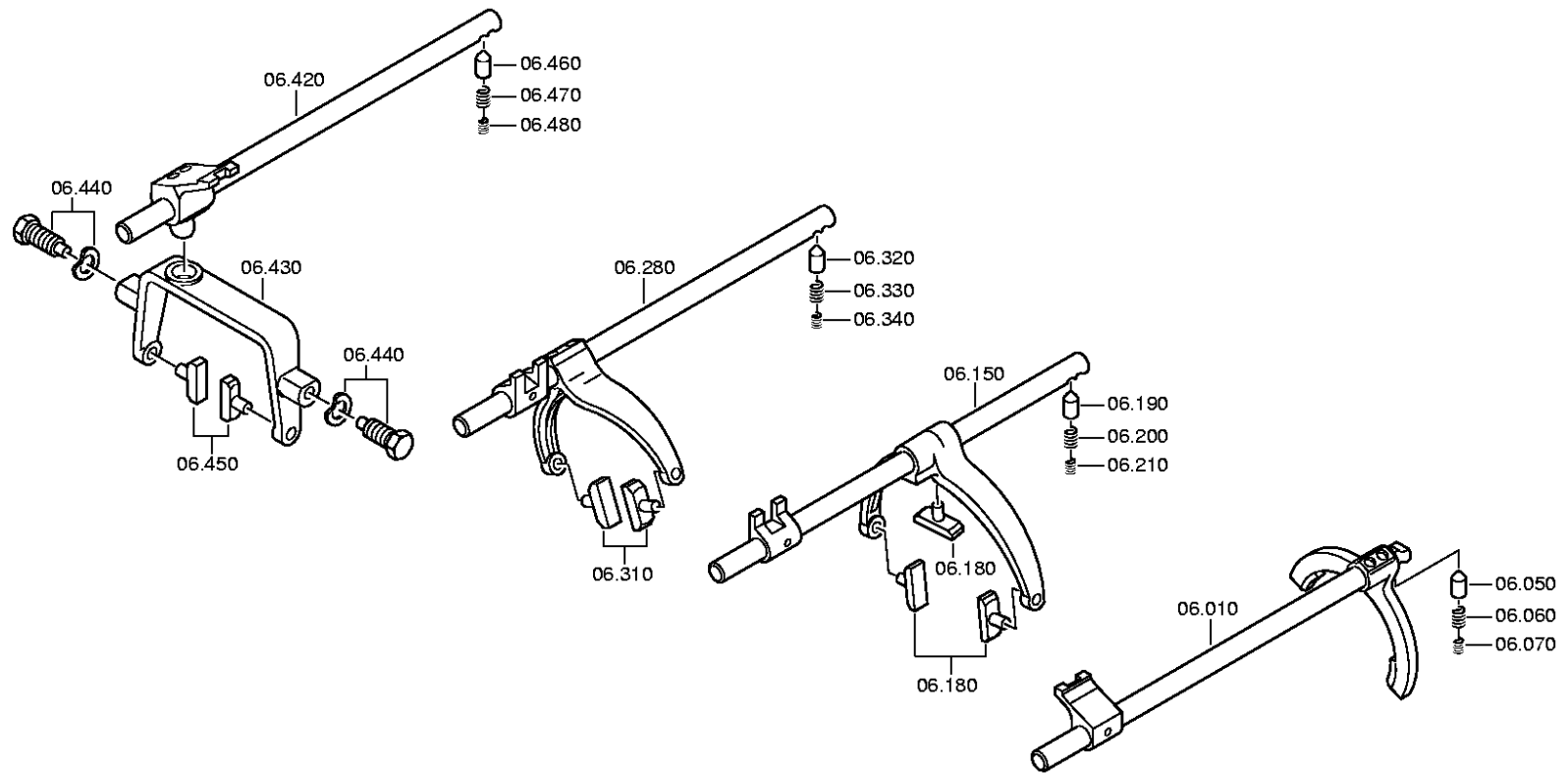

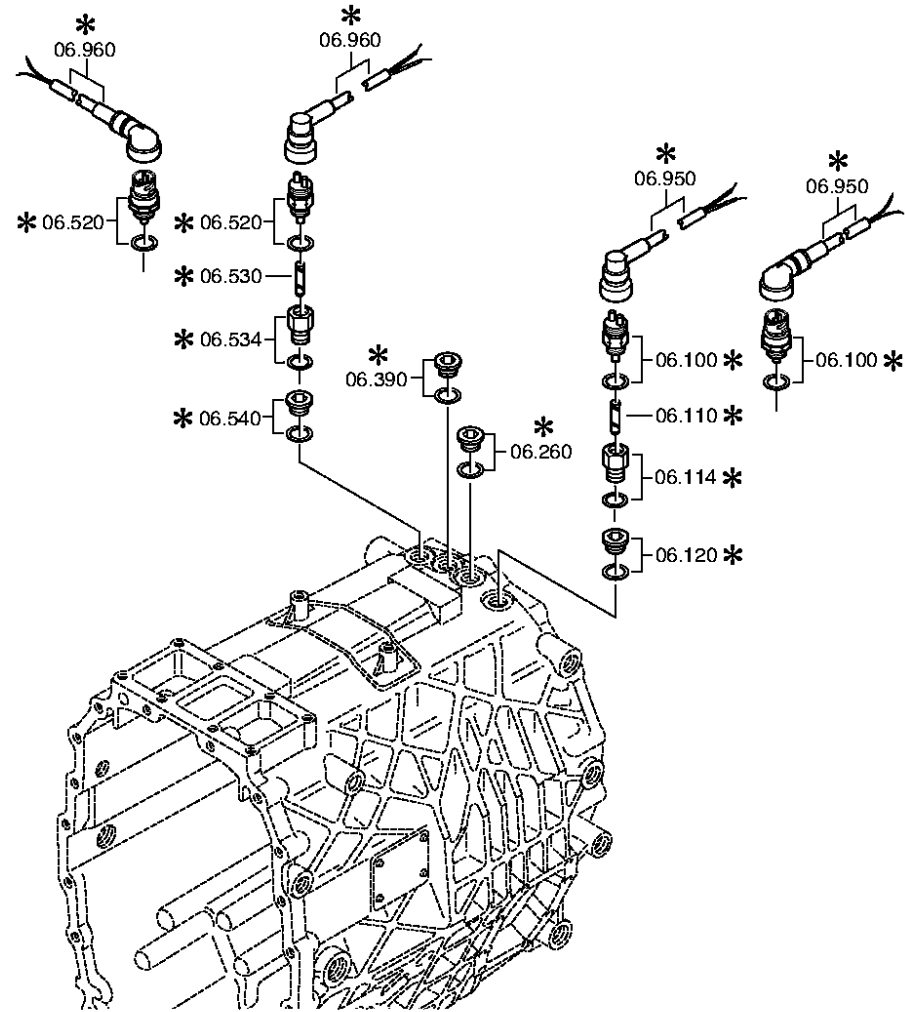



Pos.	Material number	Name	VKF	Amend. no.	Amend. start	Prod. no.	Material feature / tech. info.	OTK	External material no.	ID	Weight	SP
10	1310.206.050	GEAR SHIFT RAIL	1	C0100698 5010	00.00.0000	00.00.0000	KPL.RG *WII			3	0,000	
50	1238.306.196	DETENT PIN	1		00.00.0000		ENTHALT.IN 1238 306 281(2)			5	0,000	
60	1204.306.028	COMPRSPRING	1		00.00.0000					5	4	
70	1204.306.027	COMPRSPRING	1		00.00.0000					5	0,000	
100	---	SWITCH	1		00.00.0000		OEFF*45N.M*DICHTRING			3	0,000	
---	0501.216.474	SWITCH	1		00.00.0000		KPL.			5	0,050	
---	---	SEALING RING	1		00.00.0000		WTB 0730 150 439(2)-A= 2,20-3,60( ABSTUFUNG:0,20MM)			3	0,000	
---	0730.150.606	SEALING RING	1		00.00.0000		A=3,60			5	0,000	
---	0730.150.641	SEALING RING	1		00.00.0000		A=3,40 IN 0730 150 439(2)			5	0,000	
---	0730.150.640	SEALING RING	1		00.00.0000		A=3,20 IN 0730 150 439(2)			5	0,000	
---	0730.150.400	SEALING RING	1		00.00.0000		A=3,00 IN 0730 150 439(2)			5	0,000	
---	0730.150.399	SEALING RING	1		00.00.0000		A=2,80 IN 0730 150 439(2)			5	0,000	
---	0730.150.398	SEALING RING	1		00.00.0000		A=2,60 IN 0730 150 439(2)			5	0,000	
---	0730.150.397	SEALING RING	1		00.00.0000		A=2,40 IN 0730 150 439(2)			5	0,000	
---	0730.150.301	SEALING RING	1		00.00.0000		A=2,20 IN 0730 150 439(2)			5	0,000	
110	0731.208.134	PIN	1		00.00.0000		ENTHALT.IN 0731 208 103(2)			5	0,000	
114	---	ADAPTER	1		00.00.0000		M18X1,5*RG-ANZ*NG-ANZ			3	0,000	
---	1315.306.051	ADAPTER	1		00.00.0000					5	0,000	
---	0634.801.062	SEALING RING	1		00.00.0000		18X24			5	0,001	
150	1310.206.031	GEAR SHIFT RAIL	1	C0100663 1110	00.00.0000	00.00.0000	KPL.1+2G*WII			3	0,000	
180	1290.306.066	SLIDING PAD	3	C0100663 1110	00.00.0000	00.00.0000				5	0,037	
190	1238.306.196	DETENT PIN	1		00.00.0000		ENTHALT.IN 1238 306 281(2)			5	0,000	
200	1204.306.028	COMPRSPRING	1		00.00.0000					5	4	
210	1204.306.027	COMPRSPRING	1		00.00.0000					5	0,000	
260	---	SCREW PLUG	1		00.00.0000		M18X1,5 * 35N.M* DICHTRING			3	0,000	
---	0636.302.021	SCREW PLUG	1		00.00.0000		M18X1,5			5	0,090	
---	0634.801.062	SEALING RING	1	C0100577 3010	00.00.0000	00.00.0000	18X24			5	0,001	

VKF Incidence factor

OTK Optional technical kit

ID Identification (output code)

SP Supplier plant



Pos.	Material number	Name	VKF	Amend. no.	Amend. start	Prod. no.	Material feature / tech. info.	OTK	External material no.	ID	Weight	SP
280	1310.206.048	GEAR SHIFT RAIL	1	C0100689 0110	00.00.0000	00.00.0000	KPL.3+4G*WII			3	0,000	
310	1290.306.066	SLIDING PAD	2		00.00.0000					5	0,037	
320	1238.306.196	DETENT PIN	1		00.00.0000		ENTHALT.IN 1238 306 281(2)			5	0,000	
330	1204.306.028	COMPRSPRING	1		00.00.0000					5	4	
340	1204.306.027	COMPRSPRING	1		00.00.0000					5	0,000	
390	---	SCREW PLUG	1		00.00.0000		M18X1,5 * 35N.M* DICHTRING			3	0,000	
---	0636.302.021	SCREW PLUG	1		00.00.0000		M18X1,5			5	0,090	
---	0634.801.062	SEALING RING	1	C0100577 3010	00.00.0000	00.00.0000	18X24			5	0,001	
420	1310.206.008	GEAR SHIFT RAIL	1		00.00.0000		KPL.5+6G			3	0,000	
430	1310.306.010	SHIFT CLAMP	1		00.00.0000		ENTHALT.IN 1311 306 056(1)			5	0,000	
440	---	ARTICULATION BOLT	2		00.00.0000		M18X1,5 SK6			3	0,000	
---	1304.306.080	ARTICULATION BOLT	2	C0100780 7810	00.00.0000	00.00.0000	M18X1,5 IN 1290 306 206(1)			5	0,000	
---	0730.300.093	SPRING WASHER	2		00.00.0000					5	0,000	
450	1290.306.066	SLIDING PAD	2		00.00.0000					5	0,037	
460	1238.306.196	DETENT PIN	1		00.00.0000		ENTHALT.IN 1238 306 281(2)			5	0,000	
470	1204.306.028	COMPRSPRING	1		00.00.0000					5	4	
480	1204.306.027	COMPRSPRING	1		00.00.0000					5	0,000	
540	---	SCREW PLUG	1		00.00.0000		M18X1,5 * 35N.M* DICHTRING			3	0,000	
---	0636.302.021	SCREW PLUG	1		00.00.0000		M18X1,5			5	0,090	
---	0634.801.062	SEALING RING	1	C0100577 3010	00.00.0000	00.00.0000	18X24			5	0,001	

VKF Incidence factor

OTK Optional technical kit

ID Identification (output code)

SP Supplier plant





Bildtafel:  
 Figure: 061.07.01-1  
 Figure:  
 Figura:

je nach Stücklistenausführung  
 depending on spec. number  
 \* suivant la nomenclature  
 secondo la distinta base

Ausführung: ST \* DW-WR  
 Version: LL \* DW-SE  
 Versione:

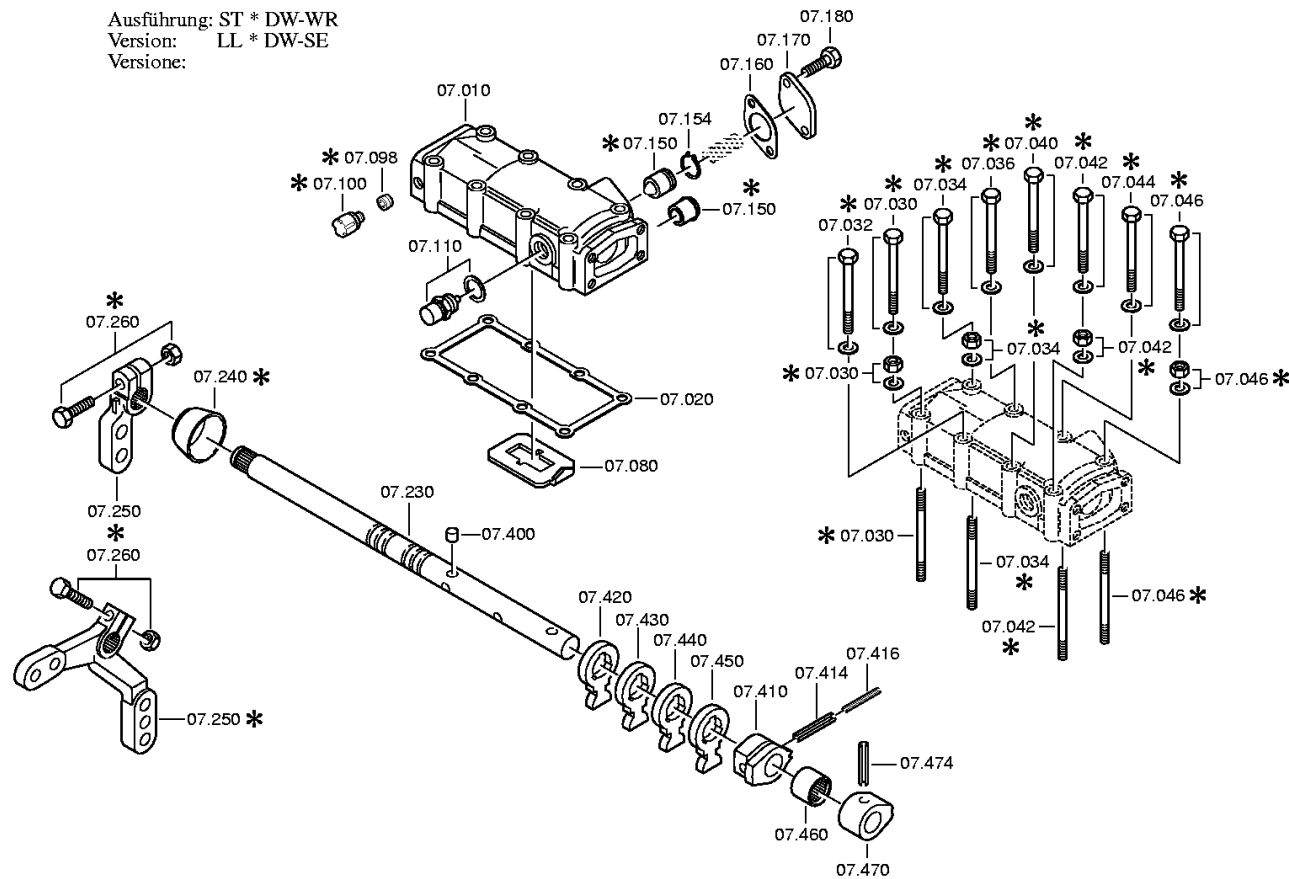



Ausführung: ST \* DW-WL  
 Version: LL \* DW-SEU  
 Versione: LR \* DW-SE

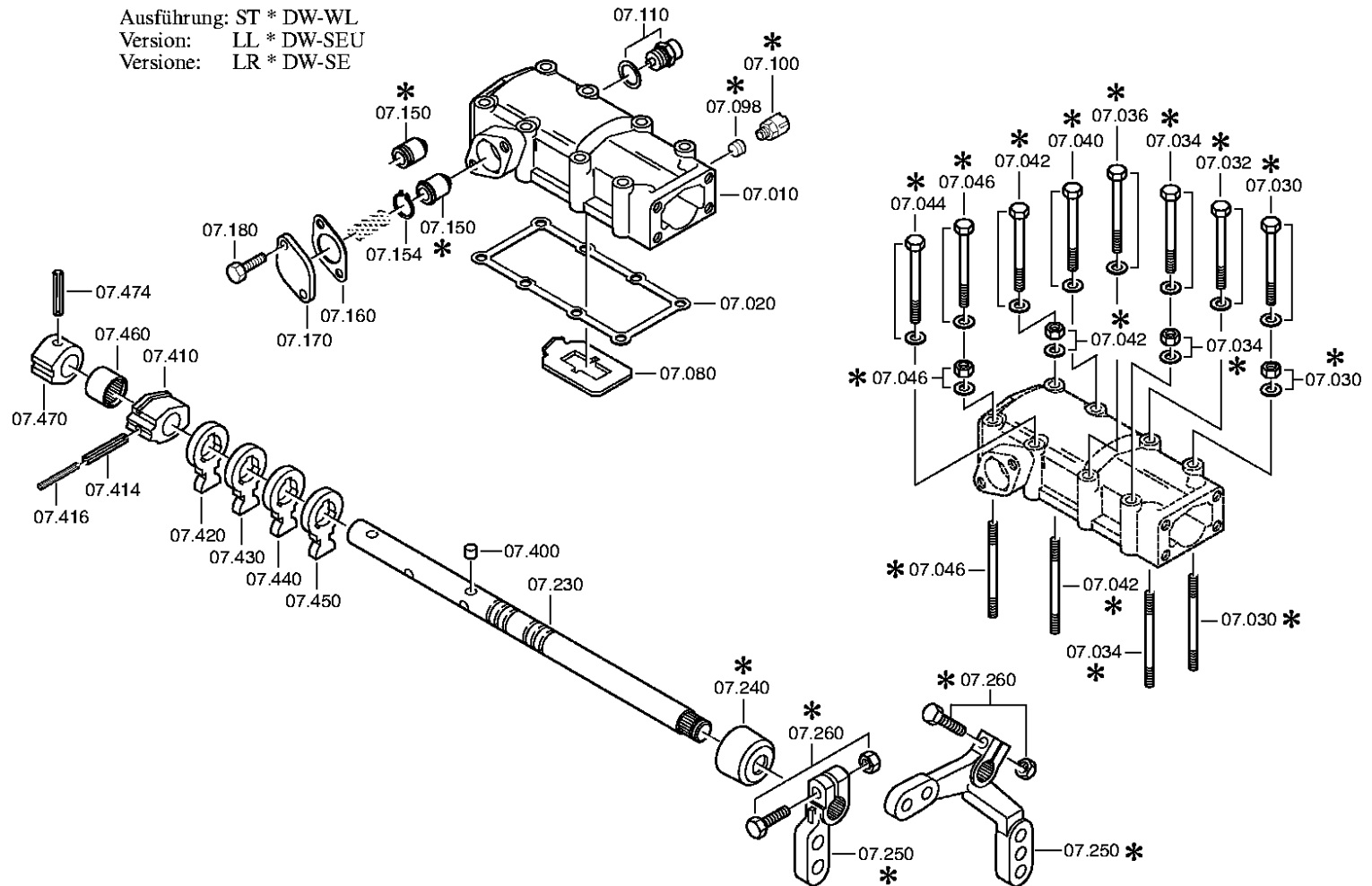



Pos.	Material number	Name	VKF	Amend. no.	Amend. start	Prod. no.	Material feature / tech. info.	OTK	External material no.	ID	Weight	SP
10	1311.307.063	GEAR SHIFT HOUSING	1		00.00.0000					5	0,000	
20	1311.307.002	GASKET	1		00.00.0000					5	0,000	
30	---	HEXAGON BOLT	1	C0100569 6410	00.00.0000	00.00.0000	M8X70 ISO4014/8.8 A3C			3	0,000	
---	0636.010.561	HEXAGON BOLT	1		00.00.0000		M8X70			5	31	
---	0630.001.075	WASHER	1		00.00.0000					5	0,002	
32	---	HEXAGON BOLT	1		00.00.0000		M8X70 ISO4014/8.8 A3C			3	0,000	
---	0636.010.561	HEXAGON BOLT	1		00.00.0000		M8X70			5	31	
---	0630.001.075	WASHER	1		00.00.0000					5	0,002	
34	---	HEXAGON BOLT	1		00.00.0000		M8X70 ISO4014/8.8 A3C			3	0,000	
---	0636.010.561	HEXAGON BOLT	1		00.00.0000		M8X70			5	31	
---	0630.001.075	WASHER	1		00.00.0000					5	0,002	
36	---	HEXAGON BOLT	1		00.00.0000		M8X70 ISO4014/8.8 A3C			3	0,000	
---	0636.010.561	HEXAGON BOLT	1		00.00.0000		M8X70			5	31	
---	0630.001.075	WASHER	1		00.00.0000					5	0,002	
40	---	HEXAGON BOLT	1	C0100569 6410	00.00.0000	00.00.0000	M8X70 ISO4014/8.8 A3C			3	0,000	
---	0636.010.561	HEXAGON BOLT	1		00.00.0000		M8X70			5	31	
---	0630.001.075	WASHER	1		00.00.0000					5	0,002	
42	---	HEXAGON BOLT	1		00.00.0000		M8X70 ISO4014/8.8 A3C			3	0,000	
---	0636.010.561	HEXAGON BOLT	1		00.00.0000		M8X70			5	31	
---	0630.001.075	WASHER	1		00.00.0000					5	0,002	
44	---	HEXAGON BOLT	1		00.00.0000		M8X70 ISO4014/8.8 A3C			3	0,000	
---	0636.010.561	HEXAGON BOLT	1		00.00.0000		M8X70			5	31	
---	0630.001.075	WASHER	1		00.00.0000					5	0,002	
46	---	HEXAGON BOLT	1		00.00.0000		M8X70 ISO4014/8.8 A3C			3	0,000	
---	0636.010.561	HEXAGON BOLT	1		00.00.0000		M8X70			5	31	
---	0630.001.075	WASHER	1		00.00.0000					5	0,002	
80	1311.307.013	SHIFTING INTERLOCK	1		00.00.0000					5	0,000	
98	---	SCREW PLUG	1		00.00.0000		M10X1 * 10N.M*O. DICHTRG.			3	0,000	
---	0636.301.039	SCREW PLUG	1		00.00.0000		M10X1			5	5	
110	---	DETENT PLUNGER	1		00.00.0000		240N*50N.M*90GRAD			3	0,000	

VKF Incidence factor

OTK Optional technical kit

ID Identification (output code)

SP Supplier plant



Pos.	Material number	Name	VKF	Amend. no.	Amend. start	Prod. no.	Material feature / tech. info.	OTK	External material no.	ID	Weight	SP
---	1304.207.025	DETENT PLUNGER	1	C0100697 0310	00.00.0000	00.00.0000	KPL. IN 1304 207 015(1)			3	0,000	
---	0634.801.332	SEALING RING	1	C0100009 3U10	00.00.0000	00.00.0000	16X22			5	0,000	
150	0501.314.501	STOP PIN	1	C0100991 5E10	00.00.0000	00.00.0000				5	0,000	
154	---	RETAINING RING	1		00.00.0000		WTB -A= 1,35- 1,75( ABSTUFUNG:0,10MM)			3	0,000	
---	0630.501.367	RETAINING RING	1		00.00.0000		20X1,75			5	0,000	
---	0630.501.368	RETAINING RING	1		00.00.0000		20X1,65			5	0,000	
---	0630.501.369	RETAINING RING	1		00.00.0000		20X1,55			5	0,000	
---	0630.501.376	RETAINING RING	1	C0100697 2910	00.00.0000	00.00.0000	20X1,45			5	0,000	
---	0630.501.377	RETAINING RING	1	C0100697 2910	00.00.0000	00.00.0000	20X1,35			5	0,000	
160	1311.307.052	GASKET	1		00.00.0000					5	0,000	
170	1311.307.054	COVER	1		00.00.0000		ENTHALT.IN 1311 307 055(2)			5	0,000	
180	0636.015.371	HEXAGON BOLT	2		00.00.0000		M6X18			5	0,006	
230	1311.307.019	GEAR SHIFT SHAFT	1		00.00.0000		ENTHALT.IN 1311 307 018(1)			5	0,000	
240	1238.307.411	PROTECTING CAP	1		00.00.0000					5	0,000	
400	0635.470.076	CYLROLLER	3		00.00.0000		8X8			5	0,000	
410	1311.307.014	DETENT PART	1		00.00.0000					5	0,000	
414	0631.329.073	SLOTPIN	1		00.00.0000		6X45			5	0,000	
416	0631.329.145	SLOTPIN	1	C0100823 1C10	00.00.0000	00.00.0000	3,5X40			5	0,000	
420	1311.307.005	DRIVER	1		00.00.0000					5	0,000	
430	1311.307.005	DRIVER	1		00.00.0000					5	0,000	
440	1311.307.005	DRIVER	1		00.00.0000					5	0,000	
450	1311.307.005	DRIVER	1		00.00.0000					5	0,000	
460	0635.303.053	NEEDLE SLEEVE	1		00.00.0000		25X32X20			5	120	
470	1310.307.004	DETENT PART	1		00.00.0000					5	0,000	
474	0631.329.071	SLOTPIN	1		00.00.0000		6X36			5	4,300	

VKF Incidence factor

OTK Optional technical kit

ID Identification (output code)

SP Supplier plant

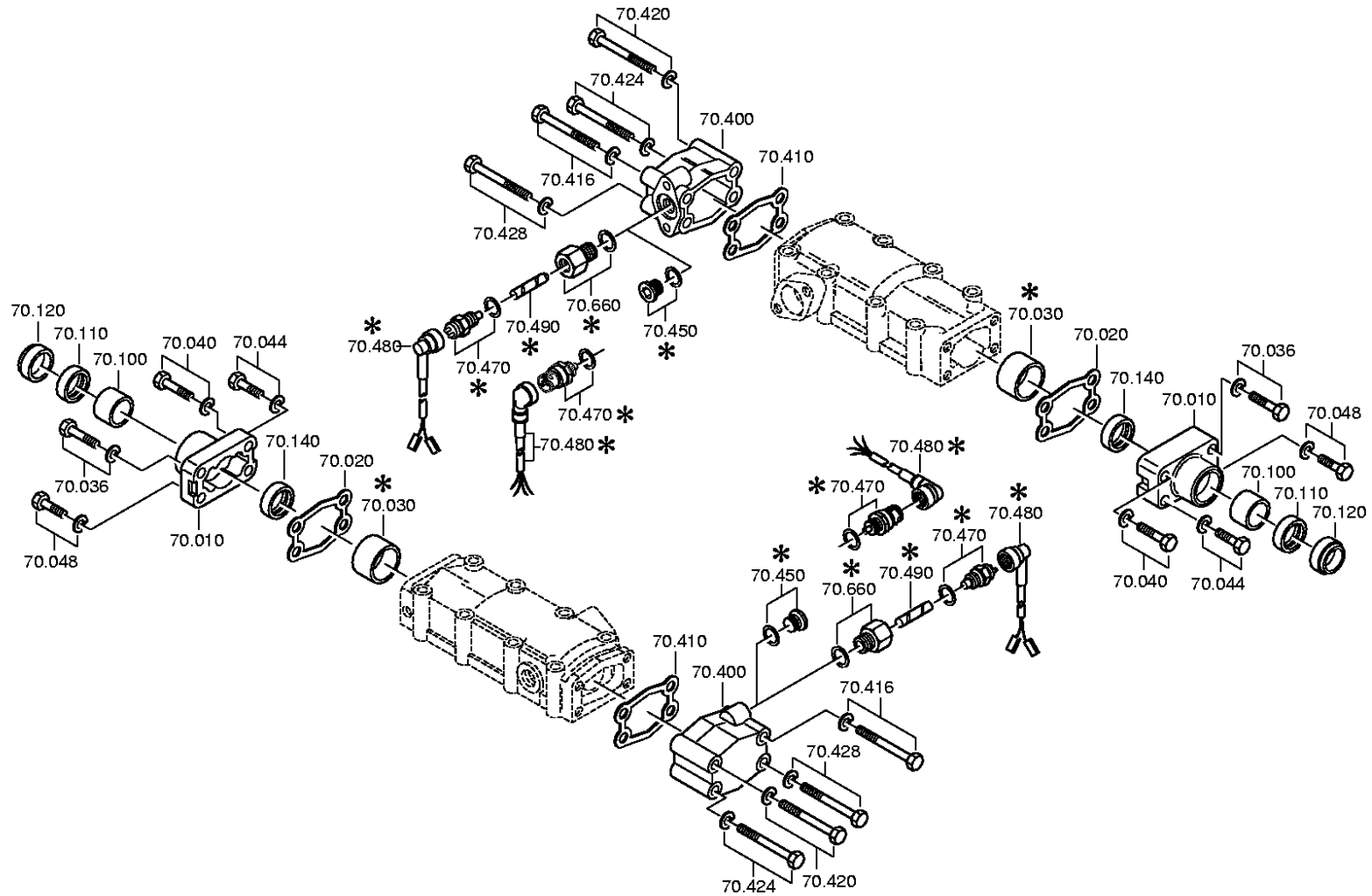



Pos.	Material number	Name	VKF	Amend. no.	Amend. start	Prod. no.	Material feature / tech. info.	OTK	External material no.	ID	Weight	SP
10	1304.307.425	GEAR SHIFT COVER	1	C0100690 9710	00.00.0000	00.00.0000				5	0,000	
20	1304.307.177	GASKET	1	C0100697 6310	00.00.0000	00.00.0000	ENTHALT.IN 1304 307 149(3)			5	0,000	
30	0730.063.180	BUSH	1	C0100558 9610	00.00.0000	00.00.0000	A=14,80 IN 0730 062 893(2)			5	0,000	
36	---	HEXAGON BOLT	1	C0100804 0A10	00.00.0000	00.00.0000	M8X30 ISO4017/8.8 A3C			3	0,000	
---	0636.015.321	HEXAGON BOLT	1		00.00.0000		M8X30			5	0,010	
---	0630.001.075	WASHER	1		00.00.0000					5	0,002	
40	---	HEXAGON BOLT	1	C0100804 0A10	00.00.0000	00.00.0000	M8X30 ISO4017/8.8 A3C			3	0,000	
---	0636.015.321	HEXAGON BOLT	1		00.00.0000		M8X30			5	0,010	
---	0630.001.075	WASHER	1		00.00.0000					5	0,002	
44	---	HEXAGON BOLT	1	C0100804 0A10	00.00.0000	00.00.0000	M8X30 ISO4017/8.8 A3C			3	0,000	
---	0636.015.321	HEXAGON BOLT	1		00.00.0000		M8X30			5	0,010	
---	0630.001.075	WASHER	1		00.00.0000					5	0,002	
48	---	HEXAGON BOLT	1	C0100804 0A10	00.00.0000	00.00.0000	M8X30 ISO4017/8.8 A3C			3	0,000	
---	0636.015.321	HEXAGON BOLT	1		00.00.0000		M8X30			5	0,010	
---	0630.001.075	WASHER	1		00.00.0000					5	0,002	
100	0730.260.330	BEARING BUSH	1	C0100710 4410	00.00.0000	00.00.0000	A=20,00 IN 0730 260 546(2)			5	0,000	
110	0634.300.302	SHAFT SEAL	1		00.00.0000		25X35X7			5	0,000	
120	0634.307.367	SCRAPER	1		00.00.0000					5	0,009	
140	---	SHAFT SEAL	1	C0100710 4410	00.00.0000	00.00.0000	25X32X5			3	0,000	
---	0634.300.020	SHAFT SEAL	1		00.00.0000		25X32X5			5	0,000	
400	1311.307.016	COVER	1		00.00.0000					5	0,000	
410	1311.307.017	GASKET	1		00.00.0000					5	0,000	
416	---	HEXAGON BOLT	1	C0100569 6410	00.00.0000	00.00.0000	M8X70 ISO4014/8.8 A3C			3	0,000	
---	0636.010.561	HEXAGON BOLT	1		00.00.0000		M8X70			5	31	
---	0630.001.075	WASHER	1		00.00.0000					5	0,002	

VKF Incidence factor

OTK Optional technical kit

ID Identification (output code)

SP Supplier plant



Pos.	Material number	Name	VKF	Amend. no.	Amend. start	Prod. no.	Material feature / tech. info.	OTK	External material no.	ID	Weight	SP
420	---	HEXAGON BOLT	1	C0100569 6410	00.00.0000	00.00.0000	M8X70 ISO4014/8.8 A3C			3	0,000	
---	0636.010.561	HEXAGON BOLT	1		00.00.0000		M8X70			5	31	
---	0630.001.075	WASHER	1		00.00.0000					5	0,002	
424	---	HEXAGON BOLT	1	C0100569 6410	00.00.0000	00.00.0000	M8X70 ISO4014/8.8 A3C			3	0,000	
---	0636.010.561	HEXAGON BOLT	1		00.00.0000		M8X70			5	31	
---	0630.001.075	WASHER	1		00.00.0000					5	0,002	
428	---	HEXAGON BOLT	1	C0100569 6410	00.00.0000	00.00.0000	M8X70 ISO4014/8.8 A3C			3	0,000	
---	0636.010.561	HEXAGON BOLT	1		00.00.0000		M8X70			5	31	
---	0630.001.075	WASHER	1		00.00.0000					5	0,002	
470	---	SWITCH	1		00.00.0000		OEFF*45N.M*DICHTRING			3	0,000	
---	0501.216.474	SWITCH	1		00.00.0000		KPL.			5	0,050	
---	---	SEALING RING	1		00.00.0000		WTB 0730 150 439(2)-A= 2,20-3,60( ABSTUFUNG:0,20MM)			3	0,000	
---	0730.150.606	SEALING RING	1		00.00.0000		A=3,60			5	0,000	
---	0730.150.641	SEALING RING	1		00.00.0000		A=3,40 IN 0730 150 439(2)			5	0,000	
---	0730.150.640	SEALING RING	1		00.00.0000		A=3,20 IN 0730 150 439(2)			5	0,000	
---	0730.150.400	SEALING RING	1		00.00.0000		A=3,00 IN 0730 150 439(2)			5	0,000	
---	0730.150.399	SEALING RING	1		00.00.0000		A=2,80 IN 0730 150 439(2)			5	0,000	
---	0730.150.398	SEALING RING	1		00.00.0000		A=2,60 IN 0730 150 439(2)			5	0,000	
---	0730.150.397	SEALING RING	1		00.00.0000		A=2,40 IN 0730 150 439(2)			5	0,000	
---	0730.150.301	SEALING RING	1		00.00.0000		A=2,20 IN 0730 150 439(2)			5	0,000	
490	0731.208.134	PIN	1		00.00.0000		ENTHALT.IN 0731 208 103(2)			5	0,000	
660	---	ADAPTER	1		00.00.0000		M18X1,5*RG-ANZ*NG-ANZ			3	0,000	
---	1315.306.051	ADAPTER	1		00.00.0000					5	0,000	
---	0634.801.062	SEALING RING	1		00.00.0000		18X24			5	0,001	

VKF Incidence factor

OTK Optional technical kit

ID Identification (output code)

SP Supplier plant

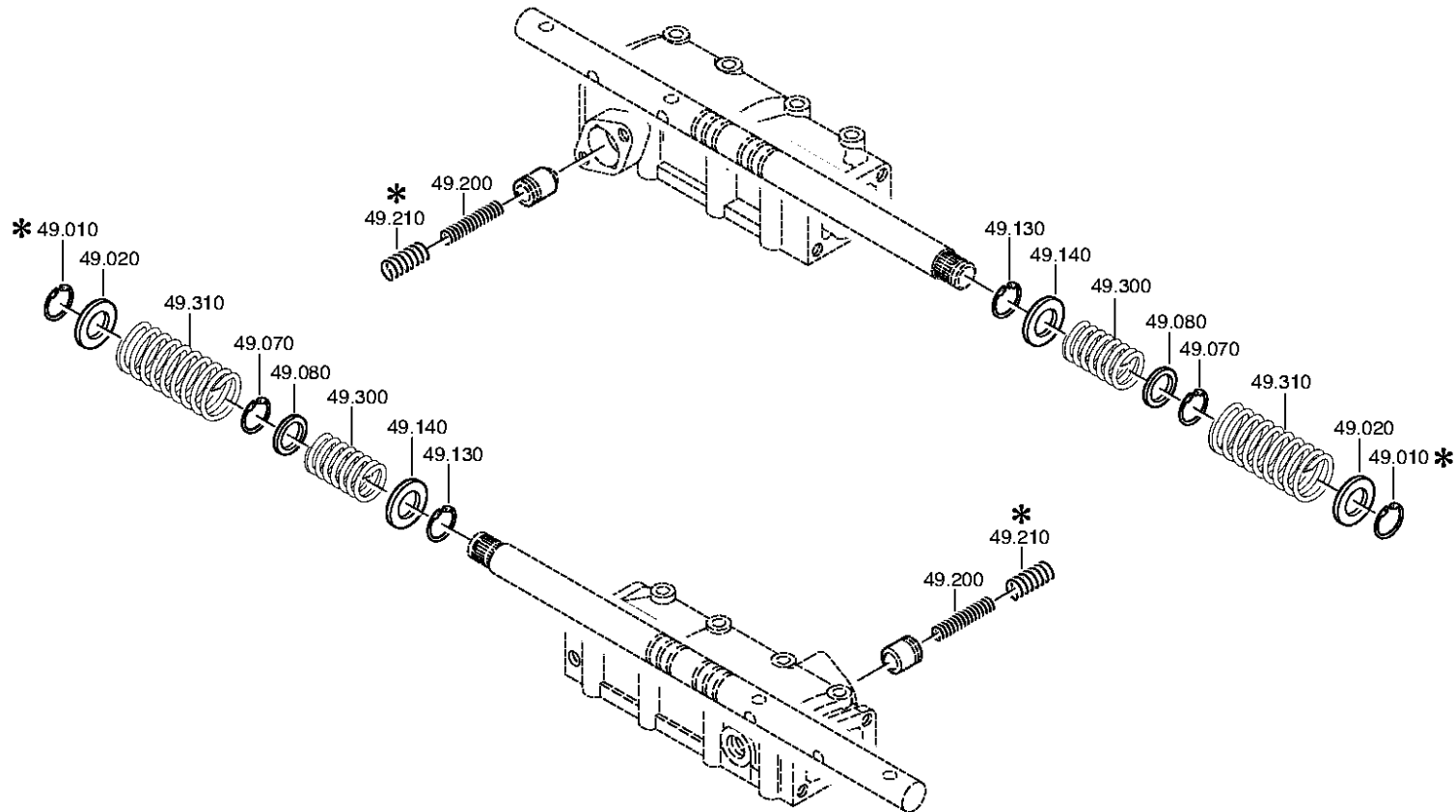





Pos.	Material number	Name	VKF	Amend. no.	Amend. start	Prod. no.	Material feature / tech. info.	OTK	External material no.	ID	Weight	SP
10	0630.531.229	V-RING	1		00.00.0000					5	0,002	
20	0730.003.740	WASHER	1		00.00.0000		A=2,00 IN 0730 003 738(2)			5	0,000	
70	0630.531.229	V-RING	1		00.00.0000					5	0,002	
80	0730.003.739	WASHER	1		00.00.0000		A=2,00 IN 0730 003 738(2)			5	0,000	3
130	0630.531.229	V-RING	1		00.00.0000					5	0,002	
140	0730.003.740	WASHER	1		00.00.0000		A=2,00 IN 0730 003 738(2)			5	0,000	
200	0732.040.819	COMPRSPRING	1		00.00.0000					5	0,000	
300	0732.041.670	COMPRSPRING	1		00.00.0000					5	0,000	
310	0732.040.630	COMPRSPRING	1		00.00.0000					5	0,000	

**VKF** Incidence factor

**OTK** Optional technical kit

**ID** Identification (output code)

**SP** Supplier plant

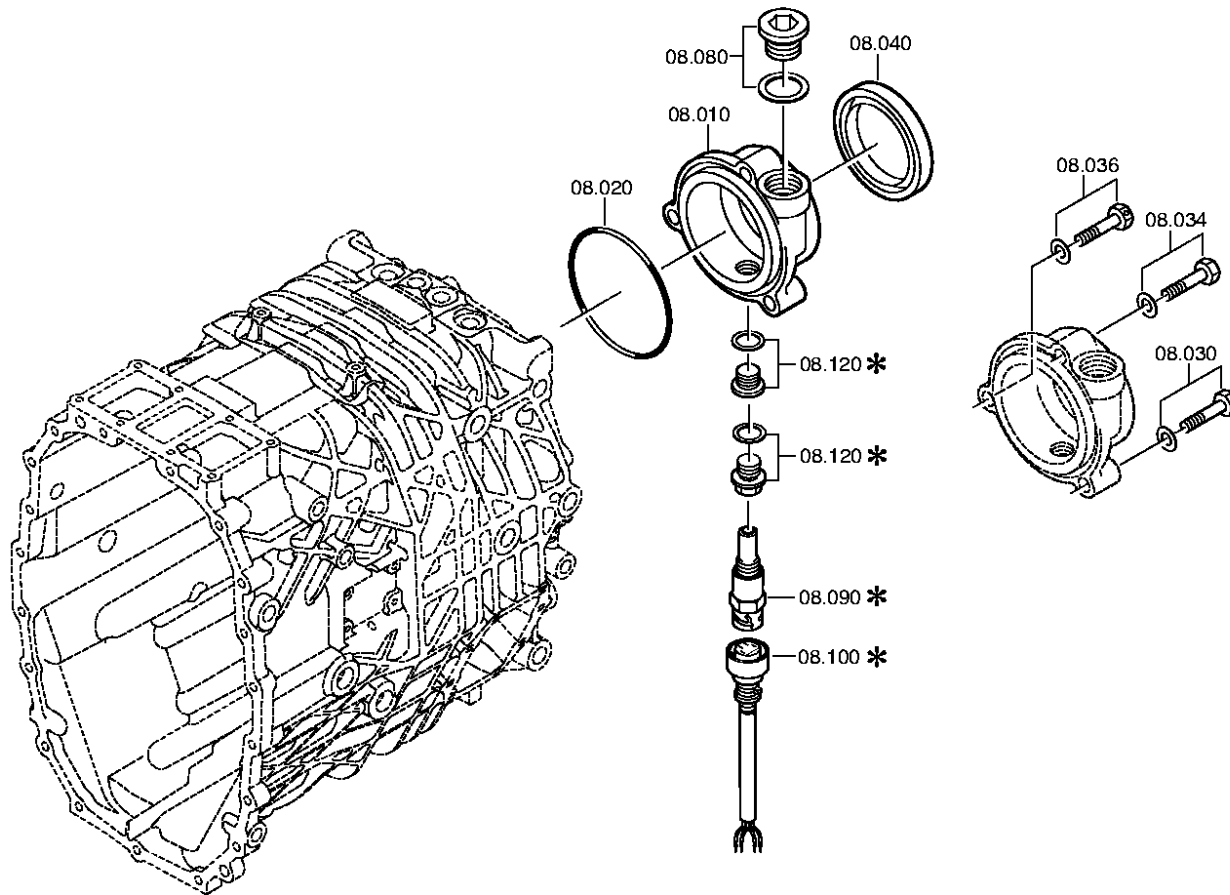



Pos.	Material number	Name	VKF	Amend. no.	Amend. start	Prod. no.	Material feature / tech. info.	OTK	External material no.	ID	Weight	SP
10	1311.301.031	SPEEDOMETER COVER	1		00.00.0000					5	0,000	
20	0634.313.100	O-RING	1	C0100613 7A10	00.00.0000	00.00.0000	113X3			5	0,000	
30	---	HEXAGON BOLT	1	C0100748 8510	00.00.0000	00.00.0000	M10X50 DIN933ALT/8.8 A3C			3	0,000	
---	0636.015.483	HEXAGON BOLT	1		00.00.0000		M10X50			5	35	
---	0630.001.048	WASHER	1		00.00.0000					5	3,400	
34	---	HEXAGON BOLT	1	C0100748 8510	00.00.0000	00.00.0000	M10X50 DIN933ALT/8.8 A3C			3	0,000	
---	0636.015.483	HEXAGON BOLT	1		00.00.0000		M10X50			5	35	
---	0630.001.048	WASHER	1		00.00.0000					5	3,400	
36	---	HEXAGON BOLT	1	C0100569 6410	00.00.0000	00.00.0000	M10X50SKDIN931ALT/8.8 A3C			3	0,000	
---	0636.010.617	HEXAGON BOLT	1		00.00.0000		M10X50			5	0,039	
---	0630.001.048	WASHER	1		00.00.0000					5	3,400	
40	0750.111.334	SHAFT SEAL	1		00.00.0000		WTB 80X100X10			3	0,000	
80	---	SCREW PLUG	1		00.00.0000		M30X1,5 *100N.M* DICHTRING			3	0,000	
---	0636.302.066	SCREW PLUG	1		00.00.0000		M30X1,5			5	0,088	
---	0634.801.324	SEALING RING	1		00.00.0000		30X36			5	0,000	
90	---	PULSE SENSOR	1		00.00.0000		L= 19,8* 45N.M*O. DICHTRING*BAJONETT			3	0,000	
---	0501.210.855	PULSE SENSOR	1	C0100964 5A10	00.00.0000	00.00.0000	KPL. IN 0501 210 854(3)			5	0,090	

VKF Incidence factor

OTK Optional technical kit

ID Identification (output code)

SP Supplier plant

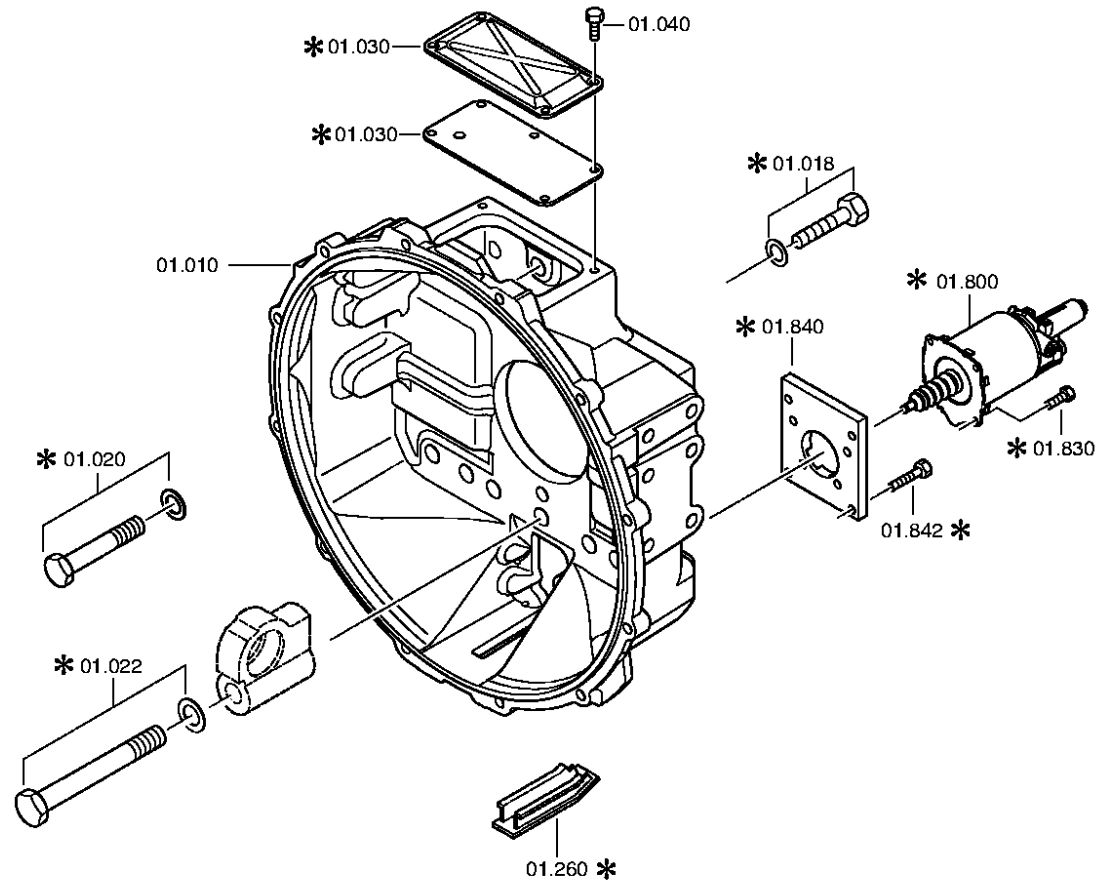

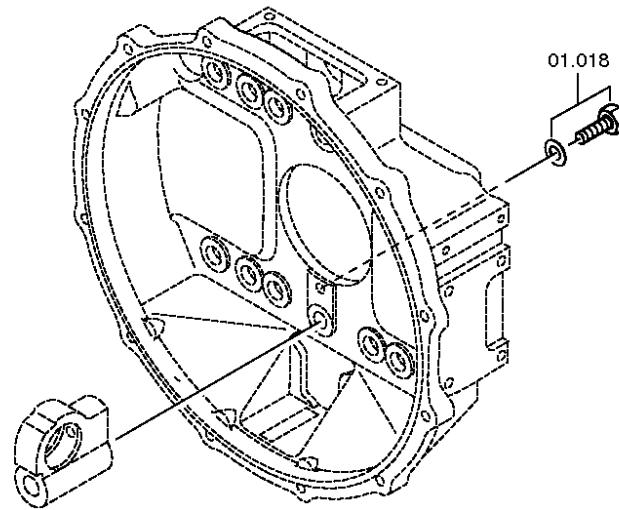



Pos.	Material number	Name	VKF	Amend. no.	Amend. start	Prod. no.	Material feature / tech. info.	OTK	External material no.	ID	Weight	SP
10	6060.201.249	BELL HOUSING	1		00.00.0000		KPL. IN 6060 201 248(1)			3	0,000	
18	---	HEXAGON BOLT	1		00.00.0000		M12X35 DIN933ALT/8.8 A3C			3	0,000	
---	0636.011.335	HEXAGON BOLT	1		00.00.0000		M12X35			5	44	
---	0630.001.049	WASHER	1		00.00.0000					5	6	
20	---	HEXAGON BOLT	9	C0100036 9B10	00.00.0000	00.00.0000	M18X1,5X85 ISO8765/8.8 A3C			3	0,000	
---	0636.020.403	HEXAGON BOLT	9		00.00.0000		M18X1,5X85			5	0,000	
---	0630.001.021	WASHER	9		00.00.0000					5	0,000	
22	---	HEXAGON BOLT	1	C0100930 0A10	00.00.0000	00.00.0000	M18X1,5X160 ISO8765/8.8A3C			3	0,000	
---	0636.020.406	HEXAGON BOLT	1		00.00.0000		M18X1,5X160			5	0,000	
---	0630.001.021	WASHER	1		00.00.0000					5	0,000	
30	0501.317.373	COVER	1		00.00.0000					5	0,000	
40	0636.015.388	HEXAGON BOLT	4		00.00.0000		M8X12			5	0,000	
210	---	PLUG	4	C0100766 5E10	00.00.0000	00.00.0000	GPN 300*F 19*D=20,7			3	0,000	
800	0501.006.795	CLUTCH CYLINDER	1		00.00.0000					5	0,000	
830	0636.015.406	HEXAGON BOLT	4		00.00.0000		M8X14			5	0,000	
840	6060.201.221	INTERMPLATE	1		00.00.0000					3	0,000	
842	0636.015.299	HEXAGON BOLT	4		00.00.0000		M8X20			5	0,010	

VKF Incidence factor

OTK Optional technical kit

ID Identification (output code)

SP Supplier plant

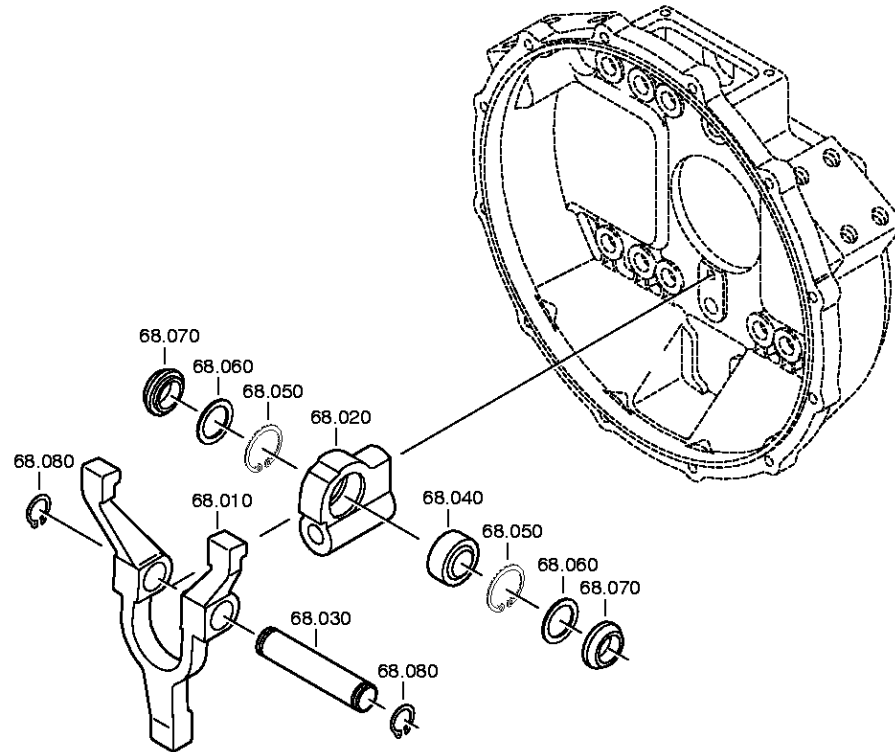



Pos.	Material number	Name	VKF	Amend. no.	Amend. start	Prod. no.	Material feature / tech. info.	OTK	External material no.	ID	Weight	SP
10	6060.206.006	RELEASE FORK	1		00.00.0000		KPL.			3	0,000	
20	6060.306.096	BRACKET	1	C0100831 0A10	00.00.0000	00.00.0000				5	0,000	
30	6060.306.086	PIN	1		00.00.0000		ENTHALT.IN 0731 201 607(2)			5	0,000	
40	0635.285.060	JOINT BEARING	1	C0100951 0B10	00.00.0000	00.00.0000				5	0,000	
50	0630.502.023	RETAINING RING	2		00.00.0000		42X1,75			5	0,010	
60	0501.315.198	SEALING RING	2		00.00.0000					5	0,000	
70	6060.306.087	SEALING WASHER	2		00.00.0000					5	0,000	
80	0630.501.020	RETAINING RING	2		00.00.0000		25X1,2			5	1,800	

**VKF** Incidence factor

**OTK** Optional technical kit

**ID** Identification (output code)

**SP** Supplier plant